

FEATURES

GLASS SHADE

- Semi-recessed shade is pressed, colored glass with an acid etched exterior finish and a matte white glazed interior décor. Available in white, amber and blue.
- Minimum flange with textured polyester powder paint finish available in matte white, matte black or satin silver.

MECHANICAL SYSTEM

- 16-gauge painted steel mounting/plaster frame with integral brackets to retain glass shade. Maximum 1-1/2" ceiling thickness.
- 16-gauge galvanized steel mounting bars with continuous 4" vertical adjustment are shipped pre-installed. Post installation adjustment possible without the use of tools from above or below ceiling.
- Galvanized steel junction box with hinged access covers and spring latch. Two combination 1/2"-3/4" and three 1/2" knockouts for straight-through conduit runs. Capacity: 8 (4 in, 4 out) No. 12 AWG conductors rated for 90°C.

ELECTRICAL SYSTEM

- Vertically-mounted, four-pin, positive-latch, thermoplastic socket.
- Class P, thermally-protected, high power factor electronic ballast mounted to the junction box.

LISTING

- Fixtures are UL Listed for thru-branch wiring, Non-IC recessed mounting and damp locations. Listed and labeled to comply with Canadian Standards.

Type Catalog number

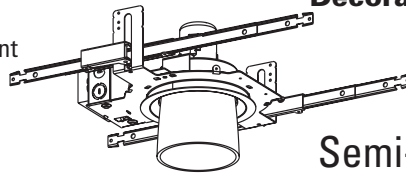

Decorative Fluorescent Downlights

6" PDRGF

Semi-recessed Glass Shade

Triple-Tube Lamp

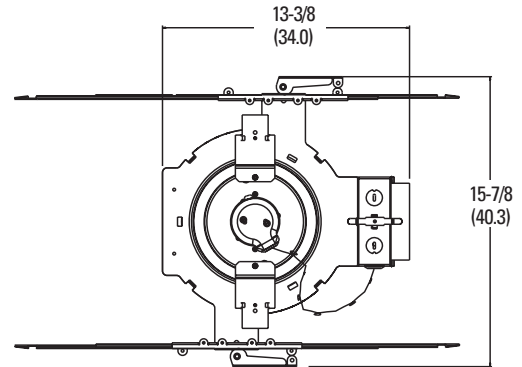

All dimensions are inches (centimeters)

Overall Diameter: 5-7/8 (15.0)
Ceiling Opening: 7-1/8 (18.1)
Overlap Trim: 7-7/8 (20.0)

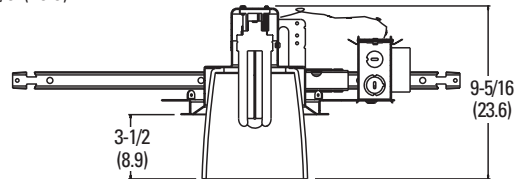

ORDERING INFORMATION

Example: **PDRGF 18TRT 6WG DBLB MVOLT**

Choose the boldface catalog nomenclature that best suits your needs and write it on the appropriate line.

PDRGF

Series	Wattage/Lamp	Shade color	Flange color	Ballast	Options
PDRGF	18TRT 26TRT 32TRT	6WG White glass 6AG Amber glass 6BG Blue glass	DWHG Matte white DBLB Matte black DNAS Satin silver	(blank) Electronic ballast ADZT ² Advance Mark 7 [®] electronic dimming ballast ADEZ ³ Advance Mark 10 [®] electronic dimming ballast DMHL ³ Lutron Compact SE [™] electronic dimming ballast DMHL3 ^{3,4} Lutron Hi-Lume [®] 1% electronic dimming ballast 2W5 ^{4,5} Lutron Tu-Wire [®] electronic dimming ballast ADAL ² Advance ROVR [™] electronic controllable ballast utilizing DALI protocol TUBDD ² Universal Lighting Technologies electronic Address PRO [®] digital dimming ballast	ELR ⁶ Emergency battery pack. Remote test switch provided ELRSD ⁶ Emergency battery pack. Remote with self diagnostics. Remote test switch provided ELRB94 ⁶ Bodine B94 emergency battery pack. Remote test switch provided BGTD ⁶ Bodine GTDM [™] generator transfer device WLP 3500°K Lamp (shipped separately) LRC ⁷ Provides compatibility with Lithonia Reloc [®] System. Lithonia Reloc System can be installed less this option with connectors provided by others. Access above ceiling required CP Chicago plenum
				Voltage	
				MVOLT ⁷	
				120	
				277	
				347	

NOTES

- Multi-volt electronic ballast capable of operating on any line voltage from 120V through 277V, 50 or 60 HZ.
- Not available with 347V.
- 120V or 277V only.
- Available in 26W and 32W only.
- 120V only.
- For dimensional changes, refer to Technical Bulletins tab.
- For compatible Reloc systems, refer to Technical Bulletins tab.

6" PDRGF Semi-recessed Glass Shade

Distribution curve	Distribution data	Output data	Coefficient of utilization	Illuminance Data at 30" Above Floor for a Single Luminaire
--------------------	-------------------	-------------	----------------------------	--

PDRGF 6AG, 18TRT amber glass, 1200 rated lumens, 1.2 s/mh, Test No. LTL15796

90° 80° 70° 60° 50° 40° 30° 0°	From 0°	Ave	Lumens	Zone	Lumens	% Lamp	pf pc	20%				50% beam angle		10% beam angle		
								80%		70%		61.2°		96.6°		
								50%	30%	50%	30%	Mount at beam height	Initial fc at beam center	Beam diameter	fc at beam edge	Beam diameter
	0	150		0° - 30°	127.2	10.6										
	5	154	15	0° - 40°	185.6	15.5	1	.27	.26	.26	.25	.25	.24			
	15	165	46	0° - 60°	264.1	22.0	2	.24	.22	.23	.22	.23	.21			
	25	145	66	0° - 90°	300.0	25.0	3	.21	.20	.21	.19	.20	.19			
	35	92	58	90° - 180°	0.0	0.0	4	.19	.17	.19	.17	.18	.17			
	45	60	46	0° - 180°	300.0	*25.0	5	.18	.16	.17	.16	.17	.15			
	55	36	32			*Efficiency	6	.16	.14	.16	.14	.15	.14			
	65	20	20				7	.15	.13	.15	.13	.14	.13			
	75	11	12				8	.14	.12	.14	.12	.13	.12			
	85	4	4				9	.13	.11	.13	.11	.12	.11			
	90	0					10	.12	.10	.12	.10	.11	.10			

PDRGF 6BG, 26TRT blue glass, 1800 rated lumens, 1.3 s/mh, Test No. LTL15792

90° 80° 70° 60° 50° 40° 30° 0°	From 0°	Ave	Lumens	Zone	Lumens	% Lamp	pf pc	20%				50% beam angle		10% beam angle		
								80%		70%		64.1°		98.6°		
								50%	30%	50%	30%	Mount at beam height	Initial fc at beam center	Beam diameter	fc at beam edge	Beam diameter
	0	240		0° - 30°	208.6	11.6										
	5	245	24	0° - 40°	316.6	17.6	1	.31	.30	.30	.29	.29	.28			
	15	264	75	0° - 60°	457.4	25.4	2	.27	.26	.27	.25	.26	.25			
	25	242	110	0° - 90°	518.4	28.8	3	.25	.23	.24	.22	.23	.22			
	35	174	108	90° - 180°	0.0	0.0	4	.22	.20	.22	.20	.21	.19			
	45	106	82	0° - 180°	518.4	*28.8	5	.20	.18	.20	.18	.19	.17			
	55	65	58			*Efficiency	6	.18	.16	.18	.16	.18	.16			
	65	36	36				7	.17	.15	.17	.14	.16	.14			
	75	18	19				8	.16	.13	.15	.13	.15	.13			
	85	5	6				9	.14	.12	.14	.12	.14	.12			
	90	0					10	.13	.11	.13	.11	.13	.11			

PDRGF 6WG, 32TRT white glass, 2400 rated lumens, 1.4 s/mh, Test No. LTL15788

90° 80° 70° 60° 50° 40° 30° 0°	From 0°	Ave	Lumens	Zone	Lumens	% Lamp	pf pc	20%				50% beam angle		10% beam angle		
								80%		70%		70.6°		108.0°		
								50%	30%	50%	30%	Mount at beam height	Initial fc at beam center	Beam diameter	fc at beam edge	Beam diameter
	0	266		0° - 30°	249.7	10.4										
	5	275	27	0° - 40°	403.5	16.8	1	.37	.35	.36	.35	.35	.33			
	15	303	86	0° - 60°	655.1	27.3	2	.32	.30	.32	.29	.30	.28			
	25	299	137	0° - 90°	878.6	36.6	3	.28	.25	.28	.25	.27	.24			
	35	247	154	90° - 180°	0.0	0.0	4	.25	.22	.25	.22	.24	.21			
	45	177	138	0° - 180°	878.6	*36.6	5	.23	.19	.22	.19	.21	.19			
	55	127	114			*Efficiency	6	.20	.17	.20	.17	.19	.17			
	65	94	94				7	.19	.15	.18	.15	.18	.15			
	75	72	76				8	.17	.14	.17	.14	.16	.14			
	85	53	53				9	.16	.13	.15	.13	.15	.12			
	90	0					10	.14	.12	.14	.11	.14	.11			

ENERGY (Calculated in accordance with NEMA standard LE-5A)					
LER.DOH	Annual* Energy Cost	Lamps	Lamp Lumens	Ballast Factor	Input Watts
15	\$16.00	(1) 18W TRT	1200	1.0	20
19	\$12.96	(1) 26W TRT	1800	1.0	28
25	\$9.76	(1) 32W TRT	2400	0.98	35

*Comparative yearly lighting energy cost per 1000 lumens

NOTES:

- For electrical characteristics consult Technical Bulletins tab.
- Tested to current IES and NEMA standards under stabilized laboratory conditions. Various operating factors can cause differences between laboratory data and actual field measurements. Dimensions and specifications are based on the most current available data and are subject to change without notice.
- Consult factory of IES file for other photometric reports.

DLCFG-110

©2007 Gotham, 7/07
DLCFG-110

gotham
An Acuity Brands Company

GOTHAM ARCHITECTURAL DOWNLIGHTING
A DIVISION OF ACUITY LIGHTING GROUP, INC.
1400 Lester Road Conyers Georgia 30012
P 800 315 4982 F 770 860 3129
www.gothamlighting.com