

FEATURES

OPTICAL SYSTEM

- Self-flanged, matte-diffuse high-impact polymer finishing trim with a durable, proprietary vapor deposition finish.
- Patented Bounding Ray™ Optical Principle design (U.S. Patent No. 5,800,050) provides lamp before lamp image and smooth transition from top of the reflector to bottom.
- One piece trim eliminates mitered flange corners and inside corner gaps.
- Upper reflector is painted a highly reflective matte white providing diffuse, even light with high efficiency.
- Proprietary Gotham diffusing lens available.

MECHANICAL SYSTEM

- 16-gauge painted steel mounting/plaster frame accommodates up to 1-1/2" thick ceiling materials.
- Patent pending adjustable aperture allows 1/4" adjustments in all directions and up to 5° of rotation allowing post-installation adjustments to ensure trim to trim alignment.
- 16-gauge galvanized steel mounting bars with continuous 4" vertical adjustments are shipped pre-installed. Post installation adjustment possible without the use of tools from above or below ceiling.
- Secondary housing adjustment system for precise, final ceiling to flange alignment.
- Galvanized steel junction box with hinged access covers and spring latch. Three combination 1/2"-3/4" and two 1/2" knockouts for straight-through conduit runs. Capacity: 8 (4 in, 4 out) No. 12 AWG conductors rated for 90°C.

ELECTRICAL SYSTEM

- Horizontally-mounted, four-pin, positive-latch, thermo-plastic socket.
- Class P, thermally-protected, high power factor electronic ballast mounted to the junction box.

LISTING

- Fixtures are UL Listed for thru-branch wiring, Non-IC recessed mounting and damp locations. Listed and labeled to comply with Canadian Standards.

Type

Catalog number

.....
.....

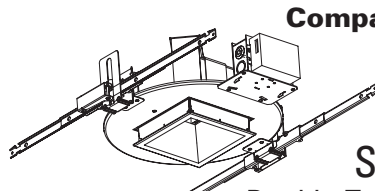

Compact Fluorescent Downlights

6" SQF

Square Open Reflector Double Twin-Tube or Triple-Tube Lamp

SIMPLY5™
LIGHTING INTELLIGENCE

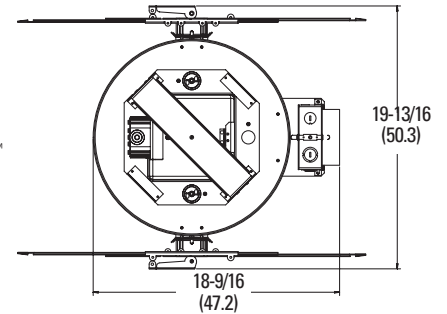

Aperture: 6 (15.2)
Ceiling Opening: 6-5/8 (16.8)
Overlap Trim: 7-3/16 (18.3)

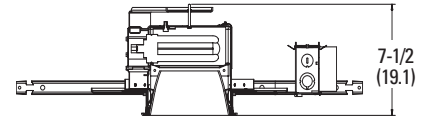

All dimensions
are inches
(centimeters)

ORDERING INFORMATION

Example: **SQF 1/26TRT 6AR MVOLT**

Choose the boldface catalog nomenclature that best suits your needs and write it on the appropriate line.

SQF

Series	Wattage/Lamp	Aperture/Trim color	Finish	Lens type		Ballast ³	Options
SQF	1/18DTT¹ 1/26DTT¹ 1/18TRT 1/26TRT 1/32TRT 1/42TRT	6AR Clear 6DSR Stepped	LD Matte-diffuse	(blank) No lens CSL Concentric square lens	Voltage MVOLT ² 120 277 347	(blank) Electronic ballast (standard) ADEZ⁵ Advance Mark 10 [®] electronic dimming ballast. Minimum dimming level 5% DMHL⁴ Lutron Compact SE™ electronic dimming ballast. Minimum dimming level 5% S5⁵ SIMPLY5™ system ballast	WLP 3500°K Lamp (shipped separately) LRC⁶ Provides compatibility with Lithonia Reloc [®] System. Lithonia Reloc System can be installed less this option with connectors provided by others. Access above ceiling required ELR⁷ Emergency battery pack. Remote test switch provided ELRSD⁷ Emergency battery pack with self-diagnostics. Remote test switch provided GMF⁸ Single, slow blow fuse GLR⁸ Single, fast blow fuse CP Chicago Plenum BDP⁹ Ballast disconnect plug HW Hardwire for S5 system; replaces Reloc [®]

NOTES

- 1 Requires 4-pin lamp. Ships as TRT fixture.
- 2 Multi-volt electronic ballast capable of operating on any line voltage from 120V through 277V, 50 or 60HZ.
- 3 For additional ballast types, refer to Technical Bulletins tab.
- 4 Available with 120V or 277V only.
- 5 SIMPLY5™ includes 9' S5 SSC Reloc wiring system. Specify voltage as 120V or 277V unless HW (hardwire) is ordered. Not available in 18W. See simply5.net for more information.
- 6 For compatible Reloc systems, refer to Technical Bulletins tab.
- 7 For dimensional changes, refer to Technical Bulletins tab.
- 8 Not available with MVOLT. Must specify voltage.
- 9 Meets codes that require in fixture disconnect.

6" SQF Square Open Reflector

Distribution curve Distribution data Output data Coefficient of utilization Illuminance Data at 30" Above Floor for a Single Luminaire

SQF 1/32TRT 6AR LD, (1) 32W CF32DT/E/IN/835 lamp, 1.0 s/mh, 2400 rated lumens, Test No. LTL16269

From 0°	Ave Lumens	Lumens	Zone Lumens % Lamp	pf pc	Coefficient of utilization						Illuminance Data at 30" Above Floor for a Single Luminaire					
					80%		20%		50%		50° beam angle		10° beam angle			
					50%	30%	50%	30%	50%	30%	Mount height	Initial fc at beam center	Beam diameter	fc at beam edge	Beam diameter	fc at beam edge
0	962		0° - 30° 686.4 28.6	1	.59	.57	.58	.56	.56	.54	8	31.8	5.7	15.9	10.8	3.2
5	961	91	0° - 40° 999.5 41.6	2	.46	.43	.45	.43	.43	.42	10	17.1	7.8	8.6	14.8	1.7
15	912	254	0° - 60° 1268.8 52.9	3	.54	.51	.53	.51	.51	.49	12	10.7	9.9	5.3	18.7	1.1
25	746	340	0° - 90° 1293.7 53.9	4	.45	.42	.45	.42	.44	.41	14	7.3	12.0	3.6	22.6	0.7
35	505	313	90° - 180° 0.0 0.0	5	.42	.38	.41	.38	.40	.37	16	5.3	14.1	2.6	26.6	0.5
45	255	196	0° - 180° 1293.7 *53.9	6	.39	.35	.38	.35	.37	.34						
55	78	73	*Efficiency	7	.36	.32	.36	.32	.35	.32						
65	17	18		8	.33	.30	.33	.30	.32	.29						
75	5	6		9	.31	.28	.31	.27	.30	.27						
85	1	1		10	.29	.26	.29	.25	.28	.25						
90	0															

SQF 1/42TRT 6AR LD, (1) 42W CF42DT/E/IN/835 lamp, 1.0 s/mh, 3200 rated lumens, Test No. LTL16273

From 0°	Ave Lumens	Lumens	Zone Lumens % Lamp	pf pc	Coefficient of utilization						Illuminance Data at 30" Above Floor for a Single Luminaire					
					80%		20%		50%		50° beam angle		10° beam angle			
					50%	30%	50%	30%	50%	30%	Mount height	Initial fc at beam center	Beam diameter	fc at beam edge	Beam diameter	fc at beam edge
0	1104		0° - 30° 770.5 24.1	1	.50	.48	.49	.48	.47	.46	8	36.5	5.6	18.2	10.8	3.6
5	1104	105	0° - 40° 1121.5 35.0	2	.46	.43	.45	.43	.43	.42	10	19.6	7.7	9.8	14.7	2.0
15	1023	286	0° - 60° 1428.4 44.6	3	.42	.39	.41	.39	.40	.38	12	12.2	9.7	6.1	18.7	1.2
25	833	380	0° - 90° 1455.7 45.5	4	.38	.35	.38	.35	.37	.34	14	8.3	11.8	4.2	22.6	0.8
35	567	351	90° - 180° 0.0 0.0	5	.35	.32	.35	.32	.34	.32	16	6.1	13.8	3.0	26.5	0.6
45	291	223	0° - 180° 1455.7 *45.5	6	.33	.30	.32	.29	.32	.29						
55	88	84	*Efficiency	7	.30	.27	.30	.27	.29	.27						
65	18	20		8	.28	.25	.28	.25	.27	.25						
75	5	6		9	.26	.23	.26	.23	.26	.23						
85	1	1		10	.25	.22	.24	.22	.24	.21						
90	0															

SQF 1/32TRT 6DSR, (1) 32W CF32DT/E/IN/835 lamp, 1.1 s/mh, 2400 rated lumens, Test No. LTL16271

From 0°	Ave Lumens	Lumens	Zone Lumens % Lamp	pf pc	Coefficient of utilization						Illuminance Data at 30" Above Floor for a Single Luminaire					
					80%		20%		50%		50° beam angle		10° beam angle			
					50%	30%	50%	30%	50%	30%	Mount height	Initial fc at beam center	Beam diameter	fc at beam edge	Beam diameter	fc at beam edge
0	699		0° - 30° 525.0 21.9	1	.54	.52	.53	.52	.51	.50	8	23.1	6.1	11.6	12.1	2.3
5	701	67	0° - 40° 793.0 33.0	2	.49	.46	.48	.46	.46	.44	10	12.4	8.3	6.2	16.5	1.2
15	691	193	0° - 60° 1128.0 47.0	3	.44	.41	.43	.40	.42	.39	12	7.7	10.5	3.9	21.0	0.8
25	579	265	0° - 90° 1201.7 50.1	4	.40	.37	.39	.36	.38	.35	14	5.3	12.8	2.6	25.4	0.5
35	432	268	90° - 180° 0.0 0.0	5	.37	.33	.36	.33	.35	.32	16	3.8	15.0	1.9	29.8	0.4
45	274	210	0° - 180° 1201.7 *50.1	6	.33	.30	.33	.29	.32	.29						
55	139	125	*Efficiency	7	.31	.27	.30	.27	.30	.26						
65	51	53		8	.28	.25	.28	.25	.28	.24						
75	15	18		9	.26	.23	.26	.23	.26	.22						
85	3	3		10	.25	.21	.24	.21	.24	.21						
90	0															

SQF 1/42TRT 6DSR, (1) 42W CF42DT/E/IN/835 lamp, 1.1 s/mh, 3200 rated lumens, Test No. LTL16275

From 0°	Ave Lumens	Lumens	Zone Lumens % Lamp	pf pc	Coefficient of utilization						Illuminance Data at 30" Above Floor for a Single Luminaire					
					80%		20%		50%		50° beam angle		10° beam angle			
					50%	30%	50%	30%	50%	30%	Mount height	Initial fc at beam center	Beam diameter	fc at beam edge	Beam diameter	fc at beam edge
0	822		0° - 30° 606.4 19.0	1	.47	.45	.46	.45	.44	.43	8	27.2	6.0	13.6	12.1	2.7
5	828	79	0° - 40° 913.4 28.5	2	.42	.40	.41	.39	.40	.38	10	14.6	8.2	7.3	16.5	1.5
15	798	223	0° - 60° 1300.9 40.7	3	.38	.35	.38	.35	.36	.34	12	9.1	10.4	4.6	20.9	0.9
25	665	305	0° - 90° 1386.7 43.3	4	.35	.32	.34	.31	.33	.31	14	6.2	12.5	3.1	25.3	0.6
35	495	307	90° - 180° 0.0 0.0	5	.32	.28	.31	.28	.30	.28	16	4.5	14.7	2.3	29.7	0.5
45	318	243	0° - 180° 1386.7 *43.3	6	.29	.26	.29	.26	.28	.25						
55	161	145	*Efficiency	7	.27	.23	.26	.23	.26	.23						
65	59	61		8	.25	.21	.24	.21	.24	.21						
75	18	20		9	.23	.20	.23	.20	.22	.19						
85	3	4		10	.21	.18	.21	.18	.21	.18						
90	0															

NOTES:

- For electrical characteristics consult Technical Bulletins tab.
- Tested to current IES and NEMA standards under stabilized laboratory conditions. Various operating factors can cause differences between laboratory data and actual field measurements. Dimensions and specifications are based on the most current available data and are subject to change without notice.