



Catalog Number:

Type:

FTT
CF



Multi-Arm Pendant Luminaire

Specifications

Reflectors - Precision formed, high performance, 95% total reflectance, segmented optics utilizing Alanod MIRO® 4 specular aluminum warranted for 25 years. Reflector optics are available in a wide variety of photometric distributions and spacing criteria.

- Optional upright. Suffix letter "U" to reflector selection.
- Custom designed reflectors for any specific application, which can increase efficiency or provide desired cutoff for comfort or lighting effect.

Construction - Hub is manufactured from 22-gauge cold rolled steel. Riveted and screwed assembly. Tool-less ballast and wiring access. Arm bodies are manufactured from 0.032" MIRO® 4 specular aluminum. Arm ends are manufactured from 0.020" MIRO® 4 specular aluminum.

- Optional hub aluminum construction, specify AL and PAF.
- Custom heavy gauge steel housing.

Finish - Standard high gloss white baked enamel, pretreated with a 5-stage iron phosphate system.

- Optional premium polyester powder coat finish, utilizing a 7-stage pretreatment process of iron phosphate, a non-chromium sealer and a de-ionized water rinse to provide superior adhesion and corrosion resistance. Specify PAF (powder coat after fabrication). Required for aluminum construction.
- Custom powder coat colors and textures are available by supplying the RAL number or by supplying a finish sample you wish to match.
- Custom galvanized steel finishes are available utilizing steel galvanized before fabrication.

Ballasts - All standard ballasts are electronic, energy saving, thermally protected, Class-P, HPF, non-PCB, Sound Rated A, UL/CSA certified where applicable and comply with © Federal Ballast Law (Public Law 100-357, 1988). Default ballast configuration is for two-lamp ballasts except for 1-lamp fixture.

Electrical - UL listed wire, rated for required temperatures, used throughout. Lamps are secured with push button locking lamp holders for ease of relamping and to reduce lamps disconnecting due to vibration or incidental contact. Luminaire is bi-national listed (UL 1598 and CSA C22.2 No. 250.0-00) and is suitable for damp locations.

Mounting - The luminaire may be monopoint mounted or suspended by chain or cable with optional eyebolt mounting kit. Specify EBM.

Warranty - Standard 1-year warranty for the fixture. Ballasts carry manufacturer warranties of 3-5 years, depending on the application.

Custom Requirements - Consult with your SpecLight Agent to develop custom solutions for any application.

Fixture Series	
FTT	63" diameter
Lamp Configuration	
1	1-lamp profile
2	2-lamp profile
Lamp Type/Wattage	
CF40	FT40
Arms	
0U/2D	0 arms up / 2 arms down
2U/0D	2 arms up / 0 arms down
Photometric Distribution	
T1	Task Beam
N1	Normal Beam
B1	Broad Beam
Reflector	
X32	MIRO® 4, 0.032"
X32U	Uplight, MIRO® 4, 0.032"
Voltage	
120	120V, 60 Hz
277	277V, 60 Hz
347	347V, 60 Hz
Ballast Configuration	
(blank)	all 2-lamp ballast
2/3	(2) 3-lamp ballast
Ballast Type	
GEB	Normal BF, ≤20% THD, IS
GEBH	High BF, ≤20% THD, IS
GEBL	Low BF, ≤20% THD, IS
Options	
AL	* Aluminum Construction, PAF
EBM	Eyebolt Mounting
PAF	* Powder Coat After Fabrication

* Hub only.



Applications

SpecLight's FTT series luminaire is a very efficient, high-intensity lighting source which may be used as an alternative to metal halide fixtures in retail, industrial and sports facilities. In addition to providing comparable light levels, the FTT offers features not typically available with high bay luminaires, such as large area coverage with no stroboscopic effects, minimal shadowing, instant on/off and increased vertical illuminance

Features

The FTT series delivers a high lumen package in a flexible arrangement of lamp compartments for areas where the number of luminaire locations must be minimized. Ideal applications are open merchandise areas, skating rinks, open manufacturing spaces, convention centers or other meeting spaces.

- Arms are constructed of MIRO®4 material in a variety of photometric distributions, with or without uplight and with or without shielding. Arms may be ordered for direct or indirect illumination.
- 2, 3, 4 and 6 arm units are available.
- Rugged hub houses all ballasts for simple maintenance.

Dimensions

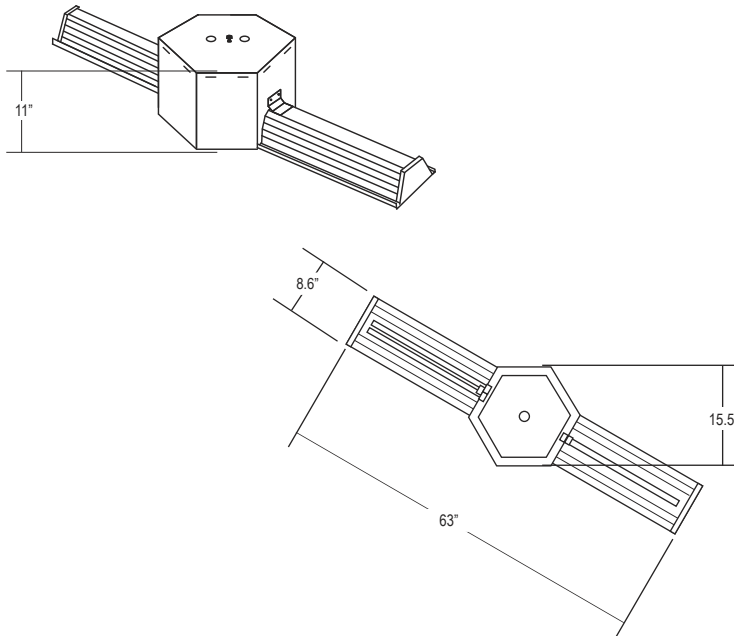

Additional Options (installed on fixture)

- Battery pack
- Motion Sensor
- Photocell
- Cord Sets
- Reloc
- Fusing

Accessories (order separately)

Photometrics

SC Across Definitions:

- Focus ($SC < 0.9$), i.e. F1X12
- Task ($0.9 \leq SC < 1.2$), i.e. T1X12
- Normal ($1.2 \leq SC \leq 1.4$), i.e. N1X12, N1D20
- Spread ($1.4 < SC \leq 1.8$), i.e. S1X12
- Broad ($1.8 < SC$), i.e. B1X12

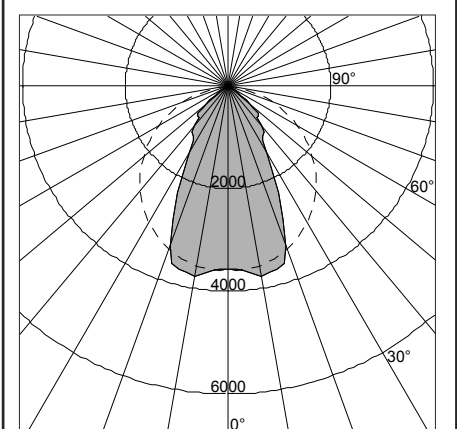

FTT 1 CF40 0U/2D T1X32
Test #T12369_S
Fixture Efficiency: 99.8%
SC Across: 0.9, SC Along: 1.3

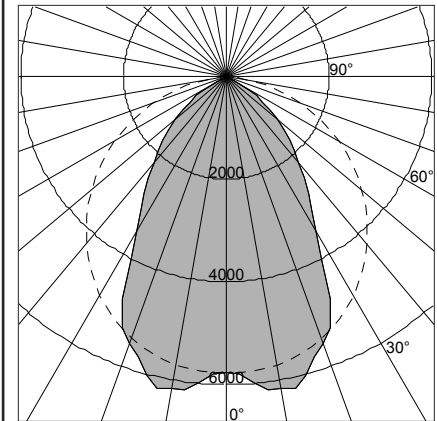

FTT 2 CF40 0U/2D T1X32
Test #T12320_S
Fixture Efficiency: 90.8%
SC Across: 1.0, SC Along: 1.3