

SAVE THESE INSTRUCTIONS

INSTALLATION INSTRUCTIONS

Directional Lensed Wallwash Housing DLWF 6 & 8

Upon receipt, thoroughly inspect for any freight damage which should be brought to the attention of the delivery carrier. Compare the catalog description listed on the packing slip with the label on the carton to ensure you have received the correct merchandise.

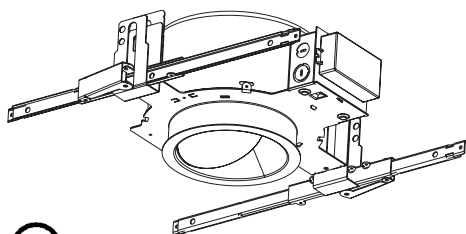

IMPORTANT SAFETY INFORMATION

For Your Protection, Read Carefully

WARNING - Risk of fire. Do not install insulation within 3 inches of fixture sides or wiring compartment, nor above the fixture in such a manner as to entrap heat.

1. Electric current can cause painful shock or serious injury unless handled properly. For your safety, always remember the following:

- Turn off the power supply.
- Ground the fixture to avoid potential electrical shocks.
- Do not handle an energized fixture or energize any fixture with wet hands, when standing on a wet or damp surface, or in water.
- Double check all electrical connections to be sure they are tight and correct.

2. Specific safety information concerning lamps:

- Match wattage of fixture and lamp exactly.
- Do not remove or insert lamp when power is on.
- Do not scratch glass or subject lamp to undue pressure as either may cause lamp breakage.
- Protect operating lamp from sources of moisture.

PRIOR TO INSTALLATION

Read and familiarize yourself with the nomenclature and instructions before starting installation.

Turn off electricity at the breaker panel or fuse box and follow National Electrical Code regulations.

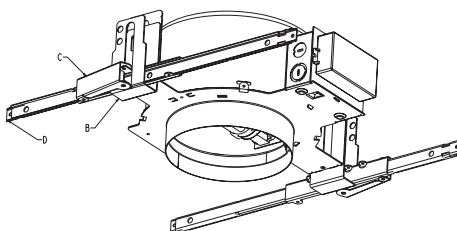

Figure 1

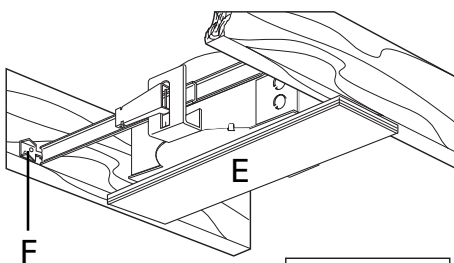

Figure 2

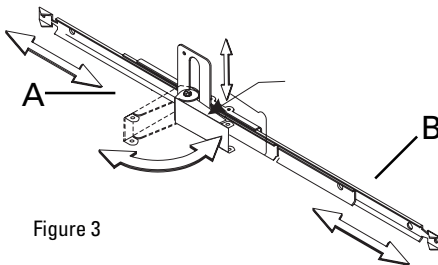
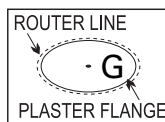

Figure 3

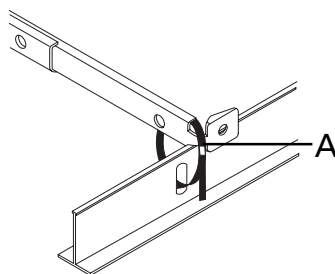

Figure 4

WOOD OR STEEL JOIST CONSTRUCTION

On 24" centers (16" or 24" O.C. for 4" fixture) utilizing solid type (non-accessible) ceiling (drywall, plaster, etc.).

USING ROUTER FOR CEILING CUTOUT

1. Open lever (C) securing bar hangers - bend ends of hangers 90° (D) to be used as nailing tabs, center in the vertical slot, and close lever (C) to lock; repeat on opposite side. Refer to Figure 1.
2. Secure a piece of plywood (E) to temporarily span the bottom of the joists to support the fixture housing while attaching the bar hangers (F) to the joists. This will position the housing correctly for drywall installer to provide pilot hole (G) to locate fixture after ceiling has been installed. Refer to Figure 2.
3. **PROCEED TO "FEED WIRE CONNECTION TO FIXTURE J-BOX" ON NEXT PAGE.** Return and complete following steps after feed wire connections have been made.
4. Using 1/8" router follow outside of plaster frame to cut hole in ceiling.
5. Loosen (2) 5/16" screws (A) 180° apart, allowing fixture to drop down so bottom edge of plaster flange will be slightly above edge of ceiling material.

FOR CEILING THICKNESS OVER 3/4" REFER TO FIGURE 5.

T-BAR CEILING INSTALLATION

1. Install ceiling panel in t-bar with ceiling opening pre-cut. Ceiling opening must be slightly larger than the outside diameter of the plaster flange.
2. Open lever (A), expand bar hangers (B) to approximately 24" and close lever to lock. Refer to Figure 3.
3. Through an adjacent opening, position the mounting frame with the plaster flange passing through the pre-cut opening with the notches on the bar hangers engaging the t-bar.
4. Secure the bar hangers to the t-bar by wire or wiretie (by others) or bending end of bar hanger. Refer to Figure 4.
5. Open lever and adjust mounting frame vertically so that the bottom edge of the plaster flange is flush or slightly above the bottom edge of the ceiling panel.
6. **PROCEED TO "FEED WIRE CONNECTION TO FIXTURE J-BOX" ON NEXT PAGE.**
7. If fine tune adjustment from below ceiling is required: Loosen (2) 5/16" screws (A) 180° apart, allowing fixture to drop down so bottom edge of plaster flange will be slightly above edge of ceiling material.

NON-STANDARD CEILING THICKNESS HOUSING INSTALLATION

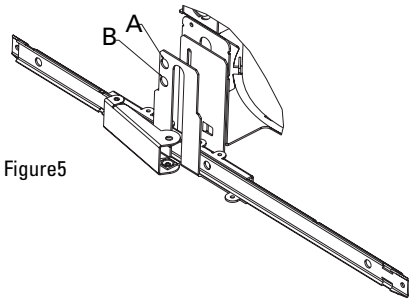

Figure 5

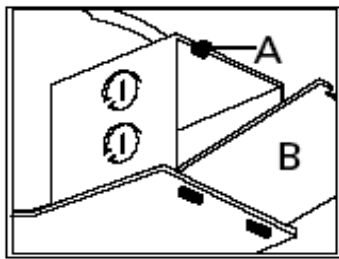

Figure 6

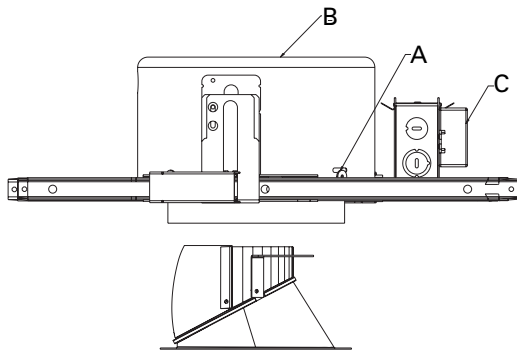

Figure 7

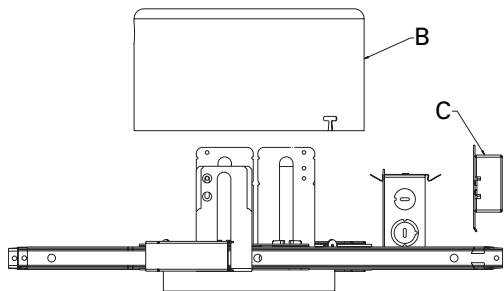

Figure 8

SAVE THESE INSTRUCTIONS

IMPORTANT INSTALLATION INFORMATION

Fixture ships configured for T-grid and standard 3/4" drywall. For thicknesses exceeding 3/4" up to 1 1/2" inches, adjust mounting bar brackets by loosening screw through hole (A), sliding bracket to upper position and tightening through hole (B).

FEED WIRE CONNECTION TO FIXTURE J-BOX Refer to Figure 6

J-box is approved for through wiring with eight No. 12 AWG conductors (4in/4out), rated 90°C or higher.

1. Remove J-box cover by releasing spring clip (A) at top and allowing cover (B) to hinge open.
2. Select knockout, remove and install appropriate box connector.
3. Install feed wire applicable to NEC and/or local requirements.
4. Complete wiring.
5. Reinstall J-box cover (B) and the wiring is complete.

BALLAST REPLACEMENT Refer to Figures 7 & 8

1. Remove trim.
2. Using a 1/4" nut driver or flat head screwdriver, loosen two screws (A) located inside of housing above galvanized frame aperture.
3. Twist black housing (B) and lift off of galvanized mounting frame.
4. Through aperture, remove ballast assembly (C), unwire ballast.
5. Install replacement in reverse order.