

Gotham Architectural Downlighting  
Compact Fluorescent Downlights

**10" AF**  
**Cross Baffle**

Horizontal Lamp  
Triple-Tube



FEATURES

**OPTICAL SYSTEM**

- Self-flanged, specular clear or semi-diffuse reflector. Patented Bounding Ray™ Optical Principle design (US Patent No. 5,800,050). Minimum flange matches reflector finish. White painted flange optional.
- Cross baffle offers superior optical cut-off with a clean aperture appearance.
- Hinged lampdoor seals upper trim for optimal fixture efficiency and the reduction of stray light in the plenum.

**MECHANICAL SYSTEM**

- 16-gauge galvanized steel construction; maximum 1-1/2" ceiling thickness.
- Telescopic mounting bars maximum of 32" and minimum of 15", preinstalled, 4" vertical adjustment.
- Toolless post-installation adjustments.
- Junction box capacity: 8 (4 in, 4 out) 12AWG rated for 90°C.

**ELECTRICAL SYSTEM**

- Horizontally mounted, four-pin, positive-latch, thermoplastic socket(s).
- Class P, thermally protected high-power-factor electronic ballast(s) mounted to the junction box (CP and EL ballast mounted on ballast tray).

**LISTING**

- Fixtures are UL Listed for thru-branch wiring, recessed mounting and damp locations. Listed and labeled to comply with Canadian standards.

**WARRANTY**

- 1-year limited warranty. Complete warranty terms located at: [www.acuitybrands.com/resources/terms-and-conditions](http://www.acuitybrands.com/resources/terms-and-conditions)

**EXAMPLE: AF 3/42TRT 10CB CGL MVOLT**

Series	Wattage/ Lamp	Aperture/ Trim color	Finish	Lens type	Voltage	Ballast	Options													
AF	1/18TRT	10CB Clear	(blank) Semi-specular	(blank) No lens	MVOLT <sup>2</sup>	(blank) Electronic ballast	<b>TRW</b> White painted flange													
	1/26TRT							<b>TRBL</b> Black painted flange												
	1/32TRT								<b>ELR<sup>6</sup></b> Emergency battery pack with remote test switch											
	1/42TRT									<b>GMF<sup>4</sup></b> Single, slow-blow fuse										
	1/57TRT <sup>1</sup>										<b>GLR<sup>4</sup></b> Single, fast-blow fuse									
	2/18TRT											<b>RIF</b> Radio interference filter								
	2/26TRT												<b>RRL<sup>7</sup></b> RELOC®-ready luminaire. Provides compatibility with Lithonia RELOC system. Access above ceiling required.							
	2/32TRT													<b>WLP</b> With 3500 K lamp (shipped separately)						
	2/42TRT														<b>CP<sup>8</sup></b> Chicago plenum (consult factory)					
	2/57TRT <sup>1</sup>															<b>NPP16D EFP</b> nLight network power/relay pack with 0-10V dimming.				
	3/18TRT																<b>NPP16D ER EFP</b> nLight network power/relay pack with 0-10V dimming. ER controls fixtures on emergency circuit.			
	3/26TRT																	<b>WL</b> Wet location; lens required		
	3/32TRT																		<b>WRL<sup>9</sup></b> Wattage restriction label	
	3/42TRT																			<b>TWS</b> Twist lock socket

ACCESSORIES order as separate catalog numbers (shipped separately)

**SCA10** Sloped ceiling adapter. Degree of slope must be specified (10D, 15D, 20D, 25D, 30D). Ex: SCA10 10D.

ORDERING INFORMATION

DIMENSIONAL DATA

All dimensions are inches (centimeters) unless otherwise noted.

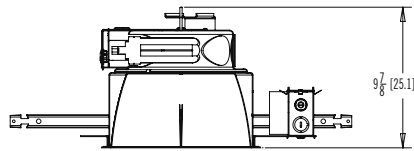
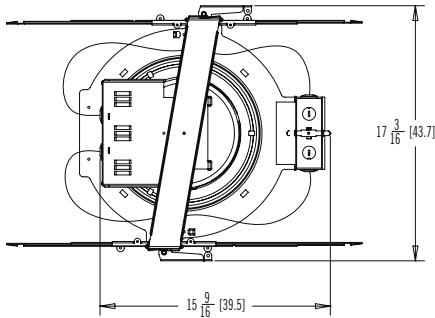

Aperture: 9-3/4 (24.8)  
 Ceiling Opening: 10-1/2 (26.7)  
 Overlap Trim: 11-1/8 (28.3)  
 Lens recess: 5-1/2 (14.0)

ELECTRICAL

Energy (Calculated in accordance with NEMA Standard LE-5)

LER.DOL	ANNUAL* ENERGY COST	LAMP DESCRIPTION	LAMP LUMENS	BALLAST FACTOR	INPUT WATTS
35	\$6.89	2/42TRT	6400	0.98	90

\* Comparative yearly lighting energy cost per 1,000 lumens

NOTES

**ORDERING NOTES**

- For use with Sylvania or Philips lamps only.
- Multi-volt electronic ballast capable of operating on any voltage from 120V through 277V, 50 or 60 Hz.
- Not available with 57W.
- Available in 120V or 277V only.
- 2/242TRT Option only available with DS (Dual Switching) option.
- For dimensional changes, refer to [TECH-140](#).
- For compatible RELOC systems, refer to [TECH-110](#).
- Not available with emergency options.
- Must specify wattage. Ex.: WRL32

Distribution Curve    Distribution Data    Output Data    Coefficient of Utilization    Illuminance: Single Luminaire 30" Above Floor

**AF 2/32TRT 10CB**    (2) CF32DT/E/IN/835, 2400 LUMENS PER LAMP, 1.3 S/MH, TEST NO. LTL9622

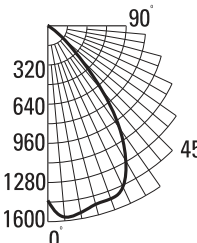

From 0°	cp.	Lumens	Zone	Lumens	%lamp	ρf ρc pw	80%		20% 70%		50%		Mount height	Initial fc at beam center	50% beam angle 66.2°		10% beam angle 89.8°	
							50%	30%	50%	30%	50%	30%			Beam diameter	fc at beam edge	Beam diameter	fc at beam edge
0°	1426		0°-30°	1280.4	26.7	1	54	52	53	51	51	50	8'	47.1	7.2	23.6	11.0	4.7
5°	1569	144	0°-40°	1938.0	40.4	2	49	47	48	46	47	45	10'	25.4	9.8	12.7	14.9	2.5
15°	1510	445	0°-60°	2334.6	48.8	3	45	43	45	42	43	41	12'	15.8	12.4	7.9	18.9	1.6
25°	1452	691	0°-90°	2343.5	48.8	4	42	39	41	38	40	38	14'	10.8	15.0	5.4	22.9	1.1
35°	1023	658	90°-180°	0.0	0.0	5	39	35	38	35	37	35	16'	7.8	17.6	3.9	26.9	0.8
45°	371	325	0°-180°	2343.5	48.8*	6	36	32	35	32	34	32						
55°	73	72			*Efficiency	7	33	30	33	30	32	29						
65°	6	7				8	31	27	30	27	30	27						
75°	2	2				9	29	25	28	25	28	25						
85°	0	0				10	27	24	27	23	26	23						
90°	0	0																

**AF 2/42TRT 10CB**    (2) CF42DT/E/IN/835, 3200 LUMENS PER LAMP, 1.3 S/MH, TEST NO. LTL9621

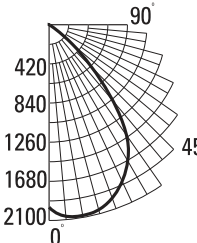

From 0°	cp.	Lumens	Zone	Lumens	%lamp	ρf ρc pw	80%		20% 70%		50%		Mount height	Initial fc at beam center	50% beam angle 66.0°		10% beam angle 91.4°	
							50%	30%	50%	30%	50%	30%			Beam diameter	fc at beam edge	Beam diameter	fc at beam edge
0°	1958		0°-30°	1735.3	27.1	1	54	53	53	52	51	50	8'	64.7	7.1	32.4	11.3	6.5
5°	2063	200	0°-40°	2627.2	41.1	2	50	48	49	47	48	46	10'	34.8	9.7	17.4	15.4	3.5
15°	2055	613	0°-60°	3161.6	49.4	3	46	43	45	43	44	42	12'	21.7	12.3	10.8	19.5	2.2
25°	1853	921	0°-90°	3173.5	49.6	4	43	39	42	39	41	38	14'	14.8	14.9	7.4	23.6	1.5
35°	1449	892	90°-180°	0.0	0.0	5	39	36	39	36	38	35	16'	10.7	17.5	5.4	27.7	1.1
45°	655	457	0°-180°	3173.5	49.6*	6	36	33	36	33	35	32						
55°	97	78			*Efficiency	7	34	30	33	30	33	30						
65°	10	9				8	31	28	31	28	30	28						
75°	3	3				9	29	26	29	26	28	26						
85°	0	0				10	27	24	27	24	27	24						
90°	0	0																

**AF 3/32TRT 10CB**    (3) CF32DT/E/IN/835, 2400 LUMENS PER LAMP, 1.2 S/MH, TEST NO. LTL9662

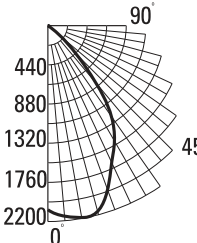

From 0°	cp.	Lumens	Zone	Lumens	%lamp	ρf ρc pw	80%		20% 70%		50%		Mount height	Initial fc at beam center	50% beam angle 62.7°		10% beam angle 88.8°	
							50%	30%	50%	30%	50%	30%			Beam diameter	fc at beam edge	Beam diameter	fc at beam edge
0°	2067		0°-30°	1687.3	23.4	1	46	45	45	44	43	43	8'	68.3	6.7	34.2	10.8	6.8
5°	2147	195	0°-40°	2548.8	35.4	2	42	41	42	40	40	39	10'	36.7	9.1	18.4	14.7	3.7
15°	2161	605	0°-60°	3001.7	41.7	3	39	37	38	36	37	36	12'	22.9	11.6	11.5	18.6	2.3
25°	1699	887	0°-90°	3012.4	41.8	4	36	34	36	33	35	33	14'	15.6	14.0	7.8	22.5	1.6
35°	1247	862	90°-180°	0.0	0.0	5	33	31	33	30	32	30	16'	11.3	16.5	5.7	26.4	1.1
45°	449	402	0°-180°	3012.4	41.8*	6	31	28	31	28	30	28						
55°	52	51			*Efficiency	7	29	26	28	26	28	25						
65°	7	8				8	27	24	26	24	26	24						
75°	2	2				9	25	22	25	22	24	22						
85°	0	0				10	23	21	23	21	23	20						
90°	0	0																

**AF 3/42TRT 10CB**    (3) CF42DT/E/IN/835, 3200 LUMENS PER LAMP, 1.2 S/MH, TEST NO. LTL9663

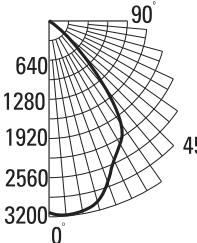

From 0°	cp.	Lumens	Zone	Lumens	%lamp	ρf ρc pw	80%		20% 70%		50%		Mount height	Initial fc at beam center	50% beam angle 61.5°		10% beam angle 88.0°	
							50%	30%	50%	30%	50%	30%			Beam diameter	fc at beam edge	Beam diameter	fc at beam edge
0°	3126		0°-30°	2531.6	26.4	1	51	49	50	49	48	47	8'	103.3	6.5	51.7	10.6	10.3
5°	3181	304	0°-40°	3764.2	39.2	2	47	45	46	44	44	43	10'	55.6	8.9	27.8	14.5	5.6
15°	3055	914	0°-60°	4407.1	45.9	3	43	41	42	40	41	39	12'	34.6	11.3	17.3	18.3	3.5
25°	2509	1313	0°-90°	4423.0	46.1	4	40	37	39	37	38	36	14'	23.6	13.7	11.8	22.2	2.4
35°	2051	1233	90°-180°	0.0	0.0	5	37	34	36	34	36	33	16'	17.2	16.1	8.6	26.1	1.7
45°	786	564	0°-180°	4423.0	46.1*	6	34	31	34	31	33	31						
55°	118	79			*Efficiency	7	32	29	31	29	31	28						
65°	11	12				8	30	27	29	26	29	26						
75°	2	4				9	28	25	27	25	27	24						
85°	0	1				10	26	23	26	23	25	23						
90°	0	0																

**PHOTOMETRY NOTES**

- Tested to current IES and NEMA standards under stabilized laboratory conditions.
- Actual performance may differ as a result of end-user environment and application.
- Consult factory or IES file for microgroove baffle, black cone or other photometric reports.