



8" SQUARE IC HOUSING

INCANDESCENT LAMPS

IC6

Project: _____

Fixture Type: _____

Location: _____

Contact/Phone: _____

PRODUCT DESCRIPTION

IC Double wall housing construction • Can be completely covered with insulation.

PRODUCT SPECIFICATIONS

Lamp One 60W A19 lamp.

Socket Medium base porcelain with nickel-plated copper screw shell.

Trims Trim selection shown below.

Labels UL listed for through-branch wiring, damp locations and IP
 • Product thermally protected against improper use of lamps
 • Union made • UL Listed/CSA certified.

Testing All reports are based on published industry procedures; field performance may differ from laboratory performance. Specifications subject to change without notice.

INSTALLATION

Real Nail® 3 Bar Hangers Telescoping, Patented (US Patent D552,969) Real Nail 3 system permits quick placement of housing anywhere within 24" O.C. joists or suspended ceilings • Integral T-bar notch and clip secures housing in suspended ceiling grid – no accessory clips required • 24" expansion stop allows quick placement of fixture in standard grid spacing • Bars scored in two locations for fast, clean breaking, allowing housing installation in tight applications • Bars captive to mounting frame • Edge-mounted for extra strength • Captive bugle-headed ring shank nail for quick one-step installation and easy removal with claw hammer for fixture relocation • Quick-Loc slot and oversized locking set screw lock fixture in position • Bar hanger foot contoured to align to bottom of construction joist • Alternate mounting holes included.

Junction Box Pre-wired junction box provided with (5) ½" and (1) ¾" knockouts, (4) Romex connectors and ground wire, UL listed/CSA certified for through-branch wiring, maximum 8 No. 12 AWG 90° C branch circuit conductors (4 in, 4 out) • Junction box provided with removable access plates • Knockouts equipped with pryout slots.

Mounting Frame 22-gauge die-formed galvanized steel mounting frame • 13½" L x 9⅝" W, (excluding bar hangers) • Rough-in section (junction box, mounting frame, housing and bar hangers) fully assembled for ease of installation.

Housing IC housing, .032" aluminum • Access door for junction box accessibility • Housing is vertically adjustable to accommodate up to a 1" ceiling thickness.

DIMENSIONS

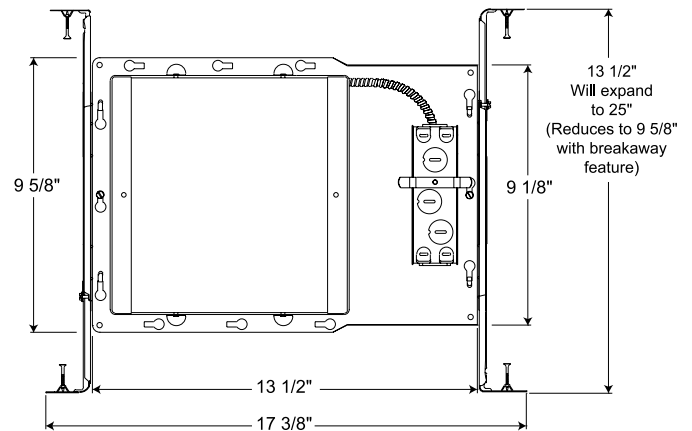
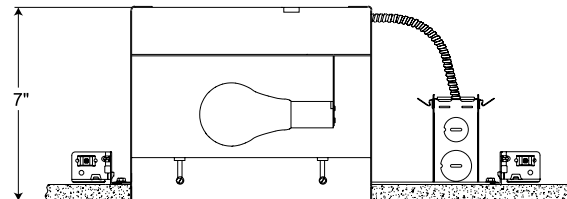

8 5/8" SQ. CEILING CUTOUT

PRODUCT CODES

Catalog Number	Input Voltage	Lamp Rating
IC6 8" Incandescent Square IC New Construction Housing	120V	60W A19

TRIMS/LAMPS

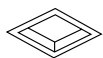

Catalog Number	Description	Max. Lamp Rating
60 WH	8" Crystal Diffuser Trim, White	60W A19
Trim Size: 9⅝" SQ.		

Housing and trim can be ordered together or separate, but will always ship separately.