

**OVERVIEW**

The CM-ADC Series of Automatic Dimming Control sensors provide continuous control of dimmable ballasts for daylight harvesting applications. Ideal for public spaces with windows like vestibules, corridors, or bathrooms; the CM-ADC works by monitoring daylight conditions in a room, then controlling a 0-10 VDC dimmable ballast so as to insure that adequate lighting levels are maintained. To add full On/Off switching to the dimming control provided by the CM-ADC, see the Technical Data Sheet on the CM-PC-ADC sensor. Additionally with the Dual Zone (-DZ) option, a second customized controlled output is provided. All units are powered by 12 to 24 VAC/VDC. With optional flash programming via the Sensor Switch VLP mobile device application, the user can easily change time delay, on mode and photocontrol settings.

**FEATURES**

- Automatically Dims/Brightens 0-10
- VDC ballasts as daylight changes
- Capable of finding optimum set-point
- Digital Set-Point Control
- Programmable via simple push-button commands
- Dimming sinks up to 20 mA
- Green LED Activity Indicator
- 100 Hr Lamp Burn-in Timer Mode

**Warranty**

Five-year limited warranty. This is the only warranty provided and no other statements in this specification sheet create any warranty of any kind. All other express and implied warranties are disclaimed. Complete warranty terms located at: [www.acuitybrands.com/support/warranty/terms-and-conditions](http://www.acuitybrands.com/support/warranty/terms-and-conditions)

**Note:** Actual performance may differ as a result of end-user environment and application. Specifications subject to change without notice



*CM ADC  
Automatic Dimming  
Control Photocell Sensor*



**ORDERING INFORMATION**

| CM ADC |   |           |             | Example: CM ADC LT        |                           |               |                         |
|--------|---|-----------|-------------|---------------------------|---------------------------|---------------|-------------------------|
| Series |   | Dual Zone |             | Visible Light Programming |                           | Temp/Humidity |                         |
| CM ADC | Automatic Dimming Control Sensor - Ceiling Mount, Low Voltage | [blank]   | Single Zone | [blank]                   | None                      | [blank]       | Standard                |
|        |   | DZ        | Dual Zone   | VLP <sup>1</sup>          | Visible Light Programming | LT            | Low Temp/ High Humidity |

Notes

1. Not available with DZ option

## LIGHT LEVEL SET-POINT

The sensor functions by comparing the amount of daylight available with a defined acceptable lighting level. This threshold, called the "set-point", is utilized in all daylight harvesting lighting control decisions. The sensor can find its optimum setpoint via the Automatic Set-Point Programming mode. In this mode, the sensor takes light readings at different dim settings and then sets the minimum light level to be the amount contributed by the artificial lights being controlled. It is assumed that the space is properly lit by design, however, if this is not the case the set-point may be easily adjusted to the occupant's preference. All modes and settings are entered digitally via a push button sequence. Once programmed, the exact value of the set-point (in foot candles) can be read out from the sensor via a series of LED flashes.

## DIGITAL SET-POINT CONTROL

Each sensor contains a microcontroller that enables the user to engage the Automatic Set-Point Programming mode or to manually set / adjust the set-point. The manual process involves calculating and inputting the exact foot-candle value of the desired set-point into the sensor. It is important to note that the set-point is the light level required at the face of the sensor and that this value will be much different than the level required at a work surface. Typically, light levels at the ceiling are 3 to 5 times less than the work surface. For example, if 50 fc is desired at the work surface, the sensor should be set at 10 fc. For best results, measure the levels at both locations using a foot-candle meter before programming the set-point.

## WIRING

### WIRING INSTRUCTIONS

Wire lead connections are Class II, 18 to 22 AWG.

#### STANDARD CM-ADC

RED - 12 to 24 VAC/VDC

BLACK - Common

VIOLET/WHITE striped - Connect to Violet wire from Zone 1's 0-10 VDC dimmable ballast. Also connect ballast Gray wire to sensor Black wire.

#### DUAL ZONE OPTION (-DZ)

Connect the additional solid VIOLET wire to Zone 2's 0-10 VDC dimmable ballast. Also connect Zone 2 ballast Gray wire to sensor Black wire.

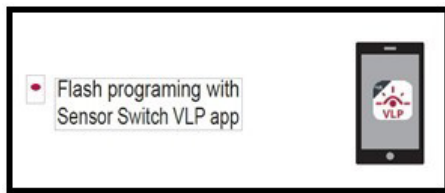
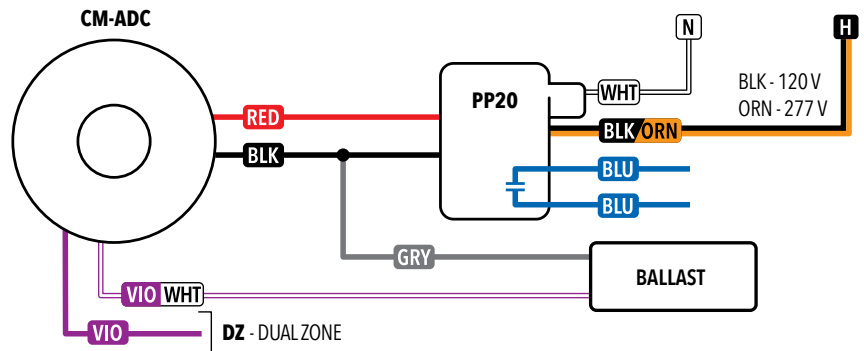

## SPECIFICATIONS

---

### Electrical

|                                   |   |
|-----------------------------------|---|
| <b>Input Ratings</b>              | Class 2 Input 24V max, 4mA<br>Class 2 Input 24V max, 16mA (-R Option) |
| <b>Relay Type</b>                 | Electrically held   |
| <b>Low Voltage Output Ratings</b> | 0-10VDC, Sinks <20mA  |
| <b>Standards/ Ratings</b>         | Energy Management Equipment, UL916 (E167435)                          |

---

### Mechanical

|                        |   |
|------------------------|---|
| <b>Dimensions</b>      | 4.55"W x 1.55"D (116mm x 40mm)              |
| <b>Mounting</b>        | Single-Gang or Octagonal Box, Surface Mount |
| <b>Color</b>           | White                                       |
| <b>Finish</b>          | Matte                                       |
| <b>Connection Type</b> | Low Voltage Leads                           |

---

### Environmental

|   |   |
|---|---|
| <b>Warrantied Operating Temperature</b> | Standard: 14°F to 176°F (-10°C to 80°C)<br>LT option: -4°F to 176°F (-20°C to 80°C) |
| <b>Relative Humidity</b>                | Up to 90%, Non-Condensing   |
| <b>Environment</b>                      | Indoor  |
| <b>Standards/ Ratings</b>               | RoHS  |