

OCCUPANCY SENSOR PROTECTIVE CAGE

Cat. No. 121KG8

For use with ceiling mount sensors

INSTALLATION INSTRUCTIONS



DESCRIPTION

The Protective Cage consists of a sturdy construction of tough 9-gage steel wire coated with heavy duty polyester. This tough, easy to install device helps prevent vandalism without significantly effecting the sensor's range of detectability.

TO INSTALL

WARNING: TO BE INSTALLED AND/OR USED IN ACCORDANCE WITH APPROPRIATE ELECTRICAL CODES AND REGULATIONS.

1. **WARNING:** TO AVOID FIRE, SHOCK, OR DEATH; **TURN OFF POWER** AT CIRCUIT BREAKER OR FUSE AND TEST THAT POWER IS OFF BEFORE DRILLING HOLES INTO ANY SURFACE!
2. Center the Protective Cage around the unit to be protected.
3. Mark the locations for holes on the mounting surface.
4. Drill holes for anchors in mounting surface.
5. Secure the cage in place using anchors, clips and screws provided (**see Mounting Diagram**).

NOTE: It is recommended that this product be placed in areas where occupancy detectors are subject to high abuse causing false triggering.

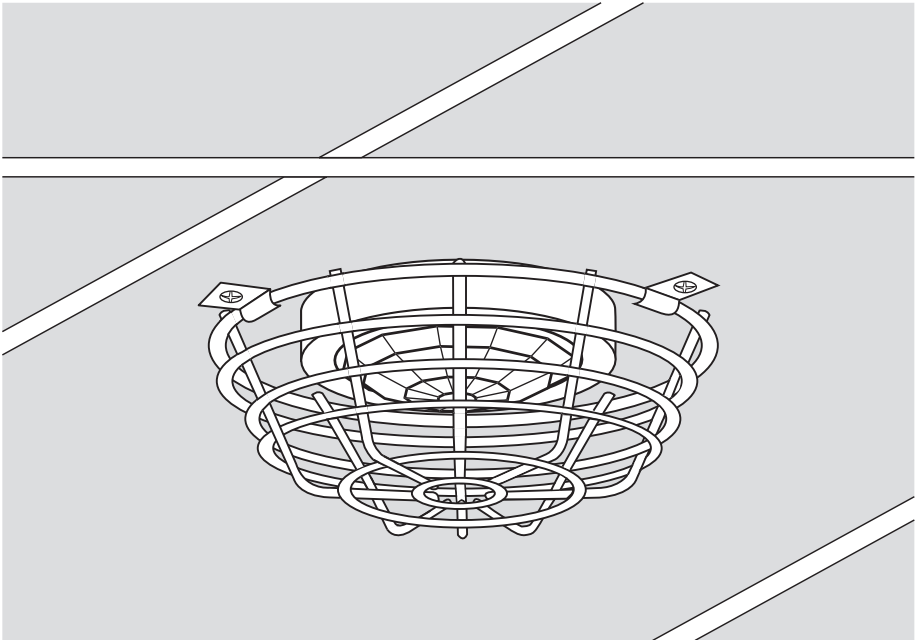

- **Reduces vandalism**
- **Cuts down maintenance costs**

Mounting Diagram

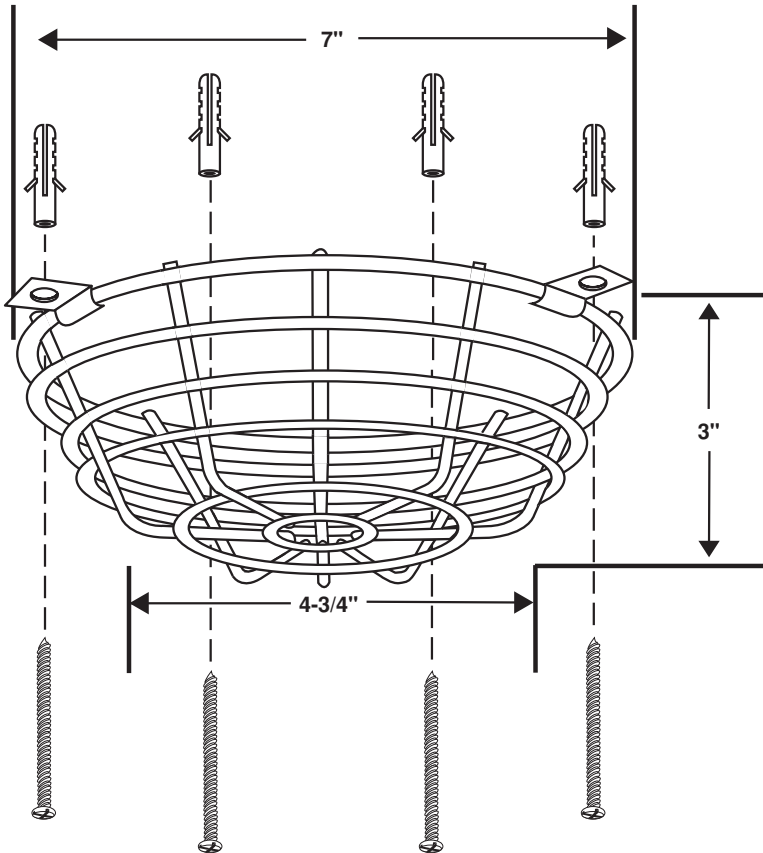

Contents:

- One (1) Occupancy Sensor Protective Cage**
- Four (4) mounting clips**
- Four (4) mounting anchors**
- Four (4) mounting screws**

GUARANTEE

Synergy Lighting Controls warrants all equipment to be free from defects in manufacturing, under normal and proper storage, installation, and use, for a period of five years. Our guarantee liability extends only to the repair or replacement of the defective part and no labor charges for correction of the defect by repair or replacement will be honored by Synergy Lighting Controls unless prior written authority has been granted by our Customer Service Department.



An **Acuity** Brands Company

DI-400-ODCCG-00A