

**READ AND FOLLOW ALL SAFETY INSTRUCTIONS!
SAVE THESE INSTRUCTIONS AND DELIVER TO OWNER AFTER INSTALLATION**

IMPORTANT SAFETY INSTRUCTIONS

▲WARNING

To reduce the risk of death, injury or property damage from fire, electric shock, cuts, abrasions, falling parts, and other hazards:

- Service of the equipment must be performed by qualified service personnel.
- Installation and maintenance must be performed by a person familiar with the construction and operation of this product and any hazards involved. All applicable codes and ordinances must be followed.
- Read this document before installing, servicing, or maintaining this equipment. These instructions do not cover all installation, service, and maintenance situations. If your situation is not covered, or if you do not understand these instructions or additional information is required, contact *Synergy Lighting Controls*.

▲WARNING

Before installing, servicing, or maintaining this equipment, follow these general precautions.

To reduce the risk of electrocution:

- Make sure the equipment is properly grounded.
- Always de-energize any equipment before connecting to, disconnecting from, or servicing the equipment.

To reduce the risk of fire:

- Use supply conductors with a minimum installation temperature rating as specified.

To reduce the risk of personal injury from cuts, abrasions:

- Wear gloves to prevent cuts or abrasions from sharp edges when removing from carton, handling and maintaining this equipment.
- Do not install a damaged equipment.

Synergy Lighting Controls, a division of *Acuity Brands Inc.*, assumes no responsibility for claims arising out of improper or careless installation or handling of this product.

SAVE THESE INSTRUCTIONS

Before You Start

1. Refer to Lithonia Supplied As Built documentation (if purchased) or the Operation Manual provided with the master dimmer cabinet for other important wiring and configuration information.
2. Always disconnect all power.
3. Install in accordance with National Electrical Code and any other codes which may apply.
4. Use only as intended.
5. Use only accessories recommended by Lithonia □□□□□□

Important Pack Mounting and Location Notes

1. Ambient Conditions:
Maximum Ambient Temperature: 104°F/40° C
Minimum Ambient Temperature: 32°F/0°C
Relative Humidity: 10-90% Non condensing
2. Pack will buzz and relay noise will be present during normal operation. Mount in an area will noise will not be objectionable.
3. Pack produces heat while operating equivalent to 3.5% of connected dimmer load. Maximum full load thermal output is 900 BTU/Hr per cabinet.
4. Pack Physical Specifications
Dimensions: 14.5"W x 19.5"H x 4.1"D
(36.8cm W x 49.5cm H x 10.4cm D)
Weight (Max): 40lbs (18kg)
5. Pack may be recess mounted if desired. Flanged door is available at additional cost.
6. Do not block air intake and air exhaust or cabinet overheating will occur. See figure 1.

Rough in Instructions

1. REMOVE COVER
Remove screws located on the edge of the front panel. Remove cover and set aside.
2. MOUNT PACK
Mount the pack to structural members as required using the four holes that have been provided in the back of the pack. Refer to figure 1.
3. CHOOSE FEED ENTRY LOCATION
Choose desired location of input circuit entry and controlled circuit exit from the pack. See figure 1.

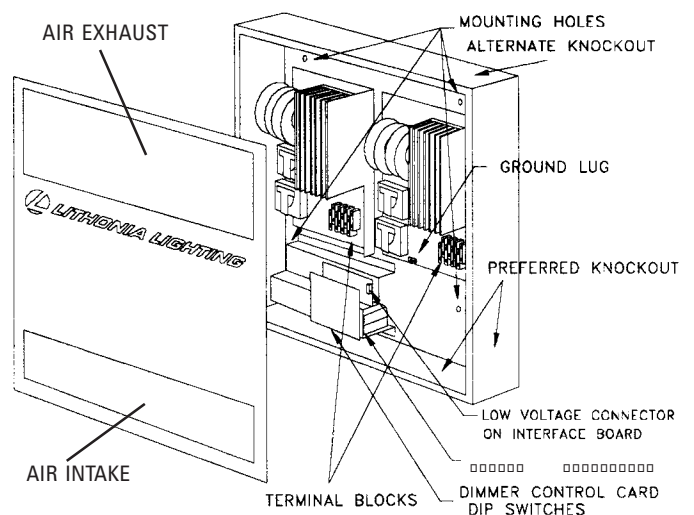

Figure 1 - Exploded View of Dimmer Pack

Circuit Wiring Notes

1. **All circuits must be on the same electrical phase.**
2. Use wire with 90°C or higher insulation rating, derate to 60°C capacity.
3. Maximum Pack Ampacity
(2) or (4) 15 or 20 amp input circuits (Derated 20% to 12 or 16 amps continuous duty at 120V, 12 or 14 amps at 277V.)
Use only at voltage listed on cabinet label.
4. Per NEC 520-27(a), the neutral is to be considered a current carrying conductor. Size wire and raceways accordingly.
5. Line, Load, and Neutral Terminal Specifications:
(1) #8 - #14 AWG or (2) #12 or #14 AWG
6. Size Branch Circuit Protection devices per NEC and any local codes which may apply. Maximum input breaker size is 20A.

Input Circuits and Load Connection

1. Prior to terminating loads on to dimmer output, determine the dimmer-to-channel assignments.
2. Check load circuits to ensure they are free from short circuits. Use as OHM meter or connect them directly to a branch breaker prior to connection to dimmer output. Connect incoming feeder conductors and controlled circuits to the terminals as shown in figure 2.
3. Once the line, load and neutral circuits have been terminated, the dimmer pack will operate all loads at full output while input #1 is energized. Turning off circuit #1 will turn off all loads. Disconnect all input circuits prior to servicing equipment or loads.

Low Voltage Wiring Connections and Switch Setting Information

This secondary S2 Minipac cabinet can be connected to:

SEQUEL MINIPAC M2 MASTER PACKS

For low voltage network terminations refer to SQMPDC M2 master dimmer pack installation instructions. Refer to "SQMPDOC" As Built Drawings (if provided) or to Sequel Minipac Operation and Maintenance Manual for instructions on how to set the dimmer card dip switches.

SEQUEL IDC MASTER CONTROL STATIONS

For low voltage network terminations refer to SQIDC control station installation instructions. Refer to "SQIDCDOC" As Built Drawings (if provided) or to Figure 3, 4 and 5 for instructions on how to set the dimmer card dip switches on the first and second dimmer pack.

SEQUEL M9 MASTER DIMMER CABINETS

For low voltage network terminations refer to SQDC dimmer cabinet installation instructions. Refer to "SEQDOC" As Built Drawings (if provided) or to Sequel Operation and Maintenance Manual for instructions on how to set the dimmer card dip switches.

SEQUEL Z9 MASTER DIMMER CABINETS

For low voltage network terminations refer to SQDC dimmer cabinet installation instructions. Refer to "SEQDOC" As Built for instructions on how to set the dimmer card dip switches.

Warranty

Lithonia Control Systems warrants all equipment to be free from defect in manufacturing, under normal and proper storage, installation, and use, for a period of one (1) year. Our guarantee liability extends only to the repair or replacement of the defective part and no labor charges for correction of the defect by repair or replacement will be honored by Lithonia Control Systems unless prior written authority has been granted by our Customer Service Department.

Installation Instructions

SEQUEL MiniPac

2UX and 4UX S2 Dimmer Pack

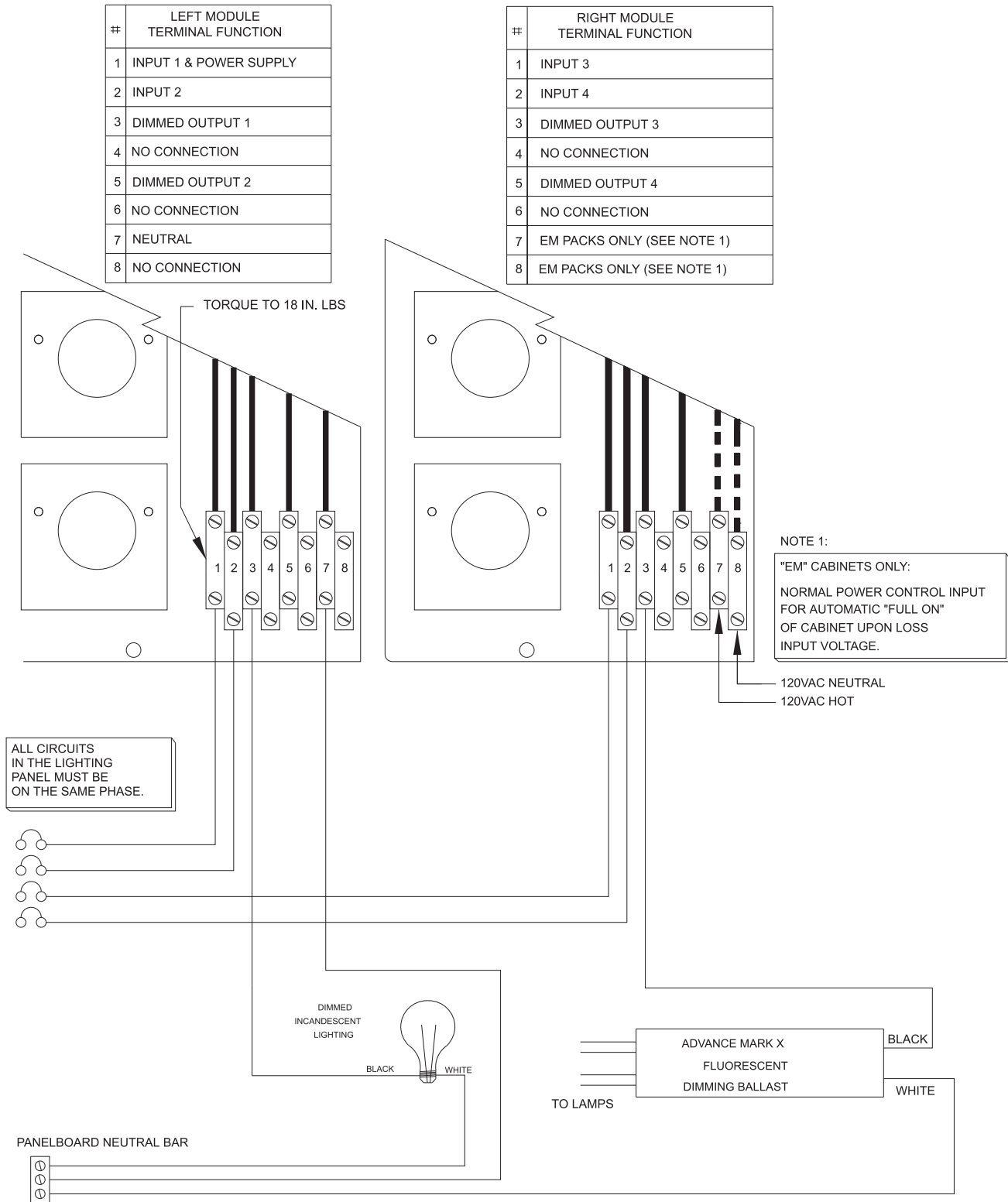

DIMMED OUTPUT MAY BE USED FOR UP TO 16 AMPS INCANDESCENT, ADVANCE MARK X, LOW VOLTAGE INCANDESCENT, NPF NEON OR NPF COLD CATHODE.

Figure 2 - Universal Dimmed Load Wiring

Figure 3 - Pack 1 Switch Settings (IDC Systems Only)

Figure 4 - Pack 2 Switch Settings (IDC and MiniPac Systems)

Figure 5 - Pack 3 Switch Settings (IDC and MiniPac Systems)