

Occupancy Sensor Power Pack

Cat. Nos. LPCS MVOLT LPCS MVOLT DCO (with HVAC relay)

Load Ratings:
20A, 2400W @ 120V, 60Hz – Incandescent
20A, 2400VA @ 120V, 60Hz – Fluorescent
20A, 5540VA @ 277V, 60Hz – Fluorescent
1 HP @ 120VAC – Motor Load
2 HP @ 240V, 60Hz – Motor Load
0.5A 125V, 1A 30VDC – HVAC Relay

Cat. No. LPCS 347 (with HVAC relay)

Load Ratings:
15A, 5200VA @ 347V, 60Hz – Fluorescent
0.5A 125V, 1A 30VDC – HVAC Relay

Occupancy Sensor Add-A-Relay

Cat. No. LAR MVOLT (with HVAC relay)

Load Ratings:
15A, 1800W @ 120V, 60Hz – Incandescent
20A, 2400VA @ 120V, 60Hz – Fluorescent
20A, 5540VA @ 277V, 60Hz – Fluorescent
15A, 5200VA @ 347V, 60Hz – Fluorescent
1 HP @ 120VAC – Motor Load
2 HP @ 240V, 60Hz – Motor Load
0.5A 125V, 1A 30VDC – HVAC Relay

For use with Litronic low-voltage Occupancy sensors

INSTALLATION INSTRUCTIONS

GUARANTEE

Synergy Lighting Controls warrants all equipment to be free from defects in manufacturing, under normal and proper storage, installation, and use, for a period of five years. Our guarantee liability extends only to the repair or replacement of the defective part and no labor charges for correction of the defect by repair or replacement will be honored by Synergy Lighting Controls unless prior written authority has been granted by our Customer Service Department.

For Technical Assistance Call:
1-800-533-2719
www.synergylightingcontrols.com

FEATURES

- Regulated 24VDC, 150mA output current (120mA for LPCS)
- Mounts inside Fluorescent Ballast cavity
- Mounts inside or outside Junction Box
- Teflon coated Class II wires for plenum wiring

RATINGS

Part Number	HVAC Relay	Power Input ¹	Power Output ²
LPCS MVOLT	No	120-277VAC, 60Hz	24VDC, 150mA 3.6W
LPCS MVOLT DCO	Yes	120-277VAC, 60Hz	24VDC, 150mA 3.6W
LPCS 347	Yes	347VAC, 60Hz	³ 24VDC, 120mA 3.0W
LAR MVOLT	Yes	24VDC, 50mA-1.2W	N/A

¹ Input voltage tolerance 10% Frequency tolerance 5%.

² Output voltage tolerance 15%, Output voltage listed at nominal.

³ Voltage range for the LPCS 347 S12 is 19-27VDC based on load and temperature conditions.

DESCRIPTION

The power pack contains a power supply, a load switching relay and on some models, a HVAC relay. The power supply provides Class II low-voltage power for Litronic low-voltage Series Occupancy Sensors. The LPCS power packs can also supply power to the LAR MVOLT, Add-A-Relay. The relay in the power pack is controlled by the occupancy sensors connected via the 22 Gauge Blue "occupancy" wire. Multiple occupancy sensors can be connected to a single power pack in order to fully cover an area.

The power packs include zero cross switching circuitry to minimize inrush current associated with incandescent and electronic ballasts. This reduces wear and tear on the relay contacts making the power pack last longer.

Application Notes:

Loads that exceed the ratings of a single power pack can be connected to an Add-A-Relay, which is powered from the low-voltage output of the power pack (LPCS). The Add-A-Relay contains the load switching and HVAC relays and is powered by an LPCS Power Pack.

1. When a lighting load exceeds a single power pack's rating, the load can be split between multiple power packs. The low voltage occupancy input (Blue wire) and DC return (Black wires) of the power packs must be connected together for all power packs to operate together as one. Connect the Blue (occupancy) wires of all power packs and sensors together. Connect the Black (return) wires of all power packs and sensors together. Connect the Red (+24VDC) wires of the sensors to the Red wires of only one power pack. Never connect the Red (+24VDC) wires of two different power packs together.

2. When more sensors are required than one power pack can supply, multiple power packs can be used to supply power to the occupancy sensor, but not switch any load. The primary power pack is the power pack switching the load. The secondary power packs only provide low voltage power to the occupancy sensor(s). Connect as many sensors to the primary power pack as possible (see current capacity section below), by connecting the Red wires of the sensors to the Red wire (+24VDC) of the primary power pack. Connect the Red wires (+24VDC) of the remaining sensors to the Red wires of the secondary power pack. Connect the Black (return) wires of all power packs and all sensors together. Connect the Blue (occupancy) wire of all sensors together to the Blue wire (occupancy) of the primary power pack. Never connect the Red (+24VDC) wires of two different power packs together.

FCC COMPLIANCE STATEMENT (LPCS MVOLT)

This equipment has been tested and found to comply with the limits for a Class A digital device, pursuant to part 15 of the FCC Rules. These limits are designed to provide reasonable protection against harmful interference when the equipment is operated in a commercial environment. This equipment generates, uses, and can radiate radio frequency energy and, if not installed and used in accordance with the instruction manual, may cause harmful interference to radio communications. Operation of this equipment in a residential area is likely to cause harmful interference in which case the user will be required to correct the interference at his own expense.

LOW-VOLTAGE CURRENT CAPACITY

NOTE: Add-a-Relay current consumption = 50mA per unit.

For LPCS MVOLT	Total Number of Sensor	+	Total Number of Add-a-Relays	≤	150mA
For LPCS 347	Total Number of Sensor	+	Total Number of Add-a-Relays	≤	120mA

INSTALLATION INSTRUCTIONS

WARNING: TO BE INSTALLED AND/OR USED IN ACCORDANCE WITH APPROPRIATE ELECTRICAL CODES AND REGULATIONS.

WARNING: IF YOU ARE NOT SURE ABOUT ANY PART OF THESE INSTRUCTIONS, CONSULT A QUALIFIED ELECTRICIAN.

OTHER CAUTIONS:

1. DISCONNECT POWER WHEN SERVICING FIXTURE OR CHANGING LAMPS.
2. USE THIS DEVICE ONLY WITH COPPER OR COPPER CLAD WIRE. WITH ALUMINUM WIRE USE ONLY DEVICES MARKED CO/ALR OR CU/AL.

TO INSTALL:

1. **WARNING:** TO AVOID FIRE, SHOCK, OR DEATH; **TURN OFF POWER** AT CIRCUIT BREAKER OR FUSE AND TEST THAT POWER IS OFF BEFORE WIRING!

2. Mount power pack per desired application:

A. To mount outside 4"x4" junction box using 2" EMT nipple, refer to **Figure 1**. Wire per Step 3A and 3B.

B. To mount inside 4"x4" junction box, refer to **Figure 2**. Wire per Step 3A and 3B.

- Ensure that conduit/cable entry clamp is located in corner of junction box.
- Dress wires to provide enough clearance when device is installed.

CAUTION: Low-voltage wires must also be dressed so they are separate from the high voltage (Class I) conductors. Refer to local building codes for the appropriate installation requirements for the low-voltage wiring. Jacketing over the low-voltage wires may be required to provide appropriate insulation from the high-voltage wiring.

C. To mount inside ballast cavity of light fixture, refer to **Figure 3A**. Wire per Step 3A and 3B.

CAUTION: Low-voltage wires must also be dressed so they are separate from the high voltage (Class I) conductors. Refer to local building codes for the appropriate installation requirements for the low-voltage wiring. Jacketing over the low-voltage wires may be required to provide appropriate insulation from the high-voltage wiring.

D. To mount outside ballast cavity of light fixture, refer to **Figure 3**. Wire per Step 3A and 3B.

3A. **Line Voltage Wiring:** Remove 5/8" (1.6 cm) of insulation from each circuit conductor. Make sure that ends of conductors are straight. Connect lead wires from Power Pack to LINE circuit per appropriate WIRING DIAGRAM as follows: Twist strands of each lead tightly and, with circuit conductors push firmly into appropriate wire connector. Screw connectors on clockwise making sure that no bare conductor shows below the wire connectors. Secure each connector with electrical tape.

3B. **Class II and HVAC Wiring:** Connect Low-Voltage wires from Power Pack to Sensor per appropriate WIRING DIAGRAM as follows: Twist strands of each lead tightly and, with circuit conductors, push firmly into appropriate wire connector. Screw connectors on clockwise making sure that no bare conductor shows below the wire connectors. Secure each connector with electrical tape.

4. Refer to sensor Installation Instructions for further details.

5. Restore power at circuit breaker or fuse. **INSTALLATION IS COMPLETE.**

WIRE DESIGNATIONS

Signal Name	Color	Gauge
Line Voltage Wires		
Line 120/277V (LPCS MVOLT)	Black	18AWG
Line 347V (LPCS 347)		
Neutral	White	18AWG
Load	Blue	14AWG
Load	Blue	14AWG
Class II Wires		
Power (24VDC)	Red	22AWG
Return	Black	22AWG
Occupancy	Blue	22AWG
HVAC Wires		
HVAC Common	Green	22AWG
HVAC NO (Normally Open)	Brown/White	22AWG
HVAC NC (Normally Closed)	Brown	22AWG

All wires rated at 105° C, 600V insulation.

Class II wires are Teflon coated, for plenum applications.

HVAC wiring is Class I and Class II rated.

OPERATION

Close Relay: When the attached occupancy sensor detects motion, it will apply +24V to the Occupancy wire causing the relay to close. This includes the HVAC relay on equipped models.

Open Relay: When the attached occupancy sensor does not detect motion the relay will open. This includes the HVAC relay on equipped models.

TROUBLESHOOTING

- **Lights Flickering**
 - Lamp has a bad connection.
 - Wires not secured firmly with wire connectors.
- **Lights do not turn ON**
 - Circuit breaker or fuse has tripped.
 - Lamp is burned out.
 - Lamp Neutral connection is not wired.
 - Low-voltage miswired. Verify wiring connections per appropriate Wiring Diagrams.
 - Line voltage miswired. Verify wiring connections per appropriate Wiring Diagrams.
- **Lights stay ON**
 - Constant motion. **To Test:** Adjust sensor; remove motion source. If unsatisfactory, move sensor.
- **Light turns ON too long**
 - Adjust sensor.

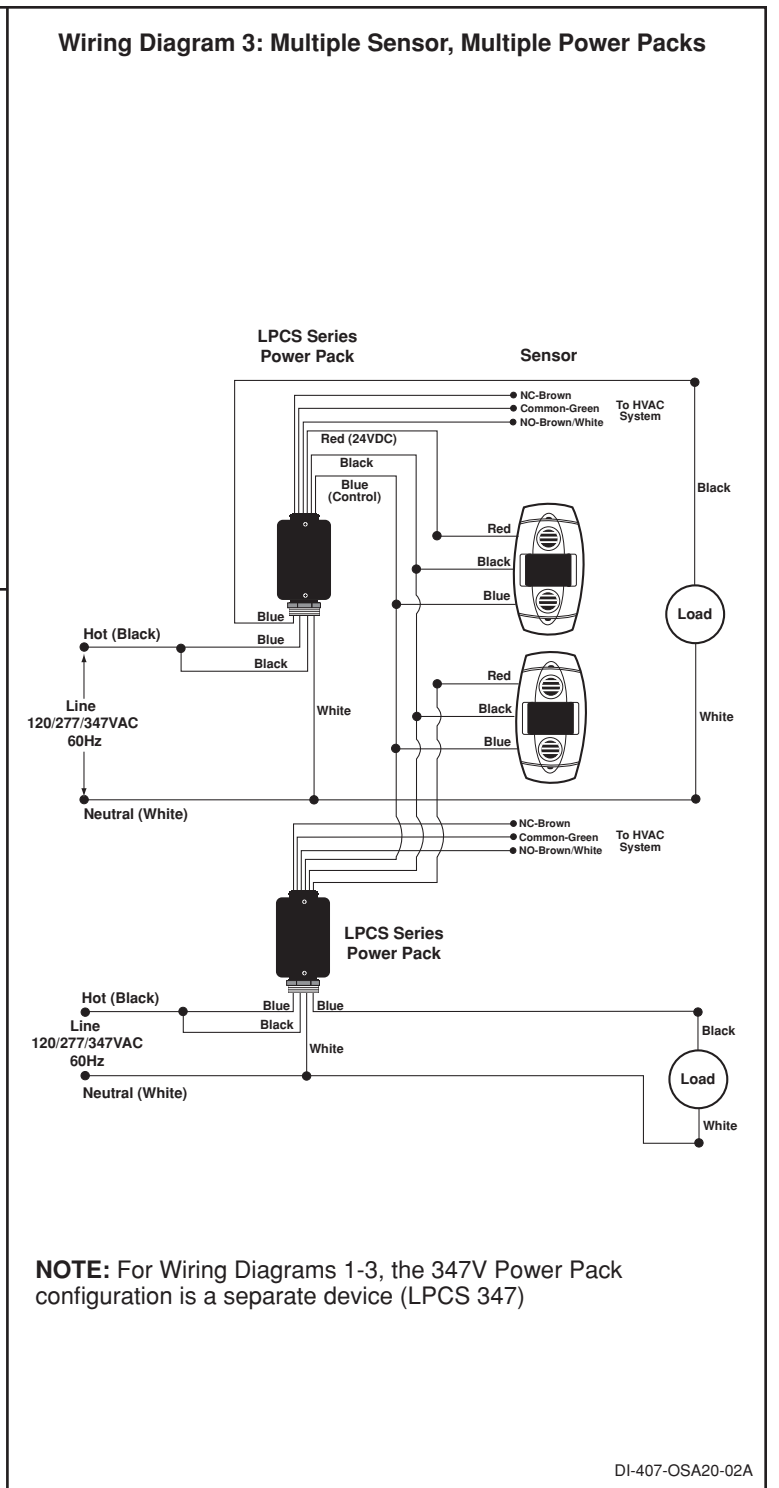
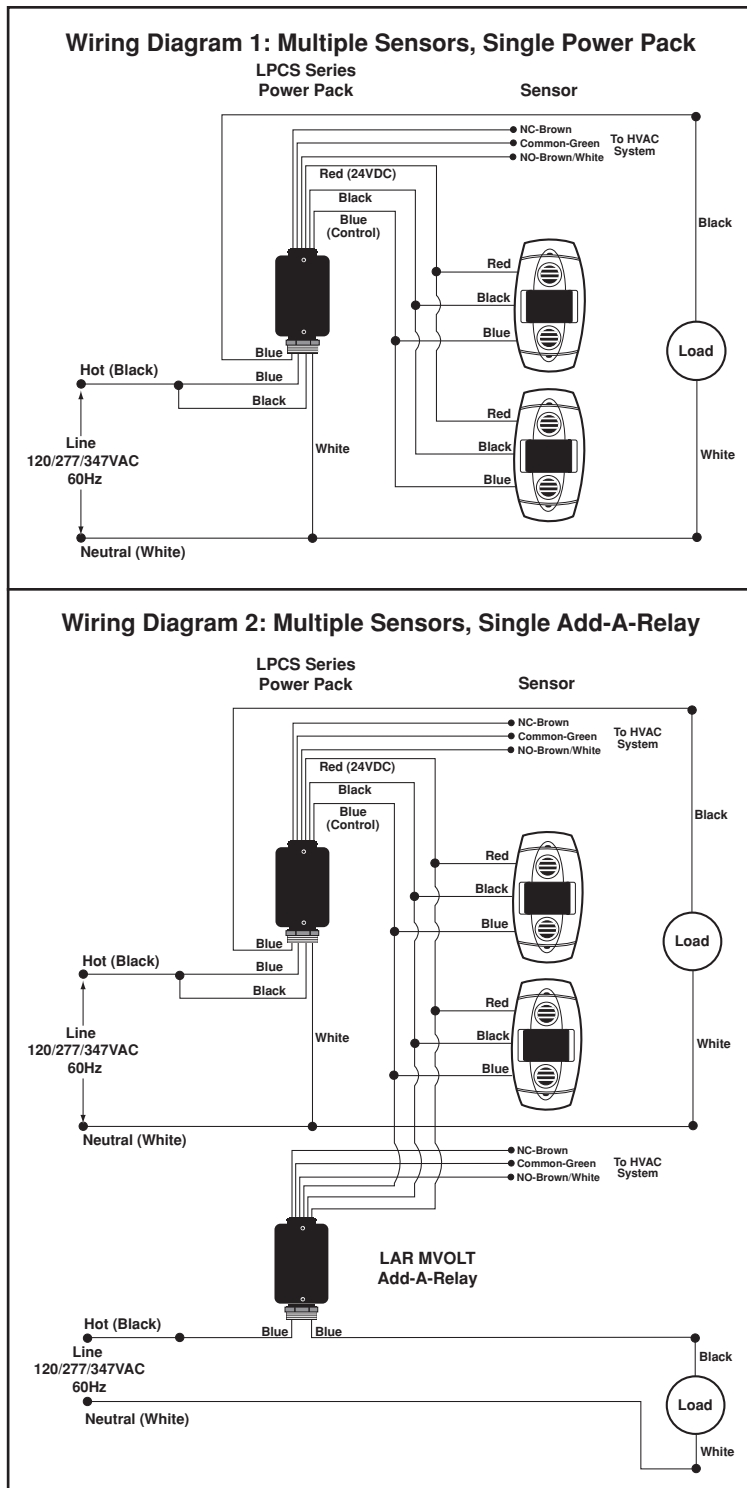
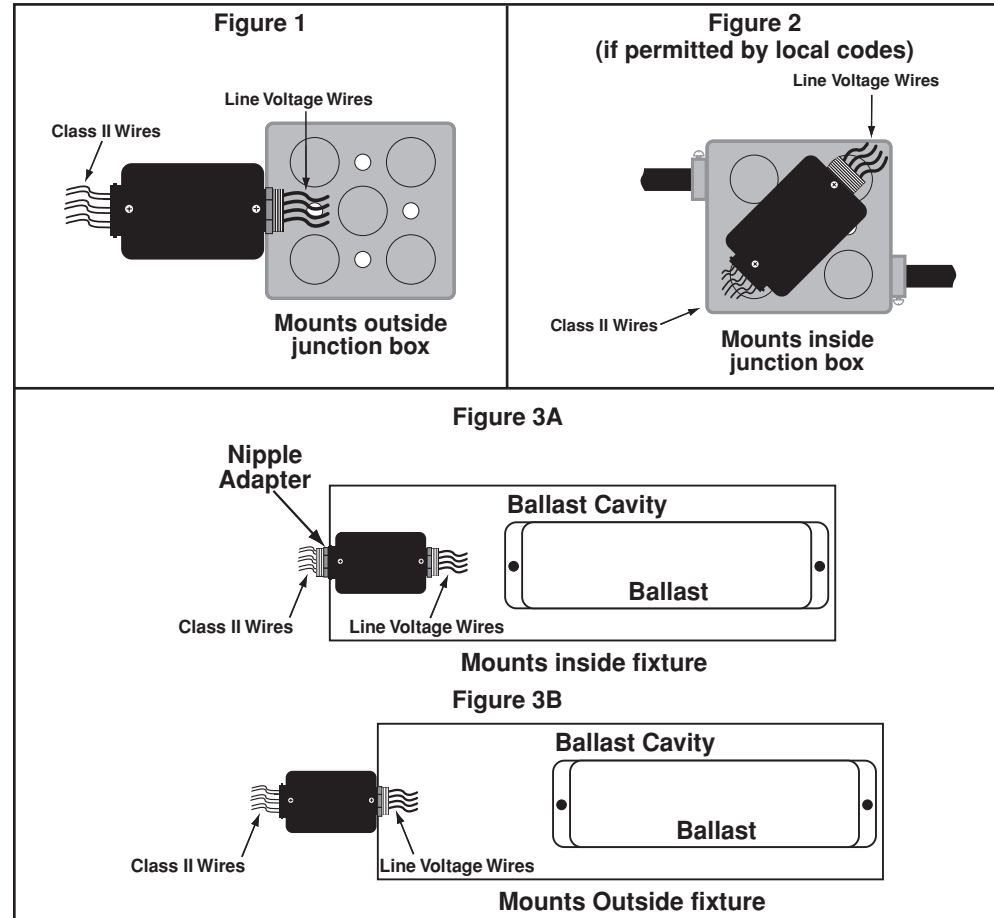

NOTE: For Wiring Diagrams 1-3, the 347V Power Pack configuration is a separate device (LPCS 347)