

Lighting controllers shall be microprocessor based and include integral astronomic clock and calendar function and provide individual schedules for each day of the week. Relays shall respond individually to any of 99 possible schedule events, including a special holiday schedule that shall have provision for 32 user entered dates. Each schedule event shall have pattern switching capability by providing for both ON and OFF commands for any combination of relays. Controllers that require individual schedule events for ON and OFF are not acceptable. Provide for user selection of automatic daylight savings time adjustment or standard time.

Program entry shall be via an integral keypad and illuminated 4-line, 80-character LCD display. The keypad shall provide individual quick-access keys that are associated with each input, each relay, and each day of the week. Programming steps shall be prompted on the display in clear alphanumeric format in such a way as to guide the user through set-up procedure. An automatic context specific help function shall activate automatically after 30 seconds of keypad inactivity. While in the help mode, the display shall provide information about the next input step required by the controller.

All programming shall be stored in non-volatile memory with clock settings backed up against loss of power by a battery rated for ten years. The program shall incorporate a warn-before-off feature that will flash the lighting to warn occupants of an impending OFF. The time delay between the WARN and the OFF shall be user selectable between one and 99 minutes.

Provide eight low voltage input terminals suitable for connection of switches, occupancy sensors or other override devices. Each shall support three-wire momentary, two-wire momentary or two-wire maintained contact closures, and shall be assignable to any combination of relays through the program. Inputs shall include a selectable time-out feature with provision for automatic time-out and reset of the input. The time-out period shall be user settable between 1 to 999 minutes. While active, each input shall provide a Class 2 voltage source suitable for illuminating switch pilot lights.

An input masking feature shall allow for automatically disabling selected switch inputs for programmed periods of time. During a masked period, activation of the switch shall not affect the status of the relays. At the duration of the prescribed time period, the switch shall automatically resume normal operation.

A dedicated photocell input shall allow connection of a remote analog photocell. The ON/OFF set points and dead band settings for photocell operation shall be adjustable through the program and not require that adjustments be made at the remote photocell location. The controller shall provide for setting individual photocell set points for all relays.

Relays shall be single-pole 20A rated or 2-pole 30A rated as scheduled. Each controller shall have provision for a maximum of eight single-pole relays, four 2-pole relays, or four single-pole and two 2-pole relays. While in operation, the current status of each relay shall be displayed and visible to the user with the enclosure access door closed. A service override switch shall be located within the enclosure and provide positive ON or OFF override of all relays.

Where indicated, provide a data line connection between the lighting controllers. The data line shall provide for the linking of control functions in the connected controllers and allow one controller to provide schedule and master override activation signals to all other connected controllers.

The enclosure shall be NEMA 1 rated construction with a hinged locking door and shall provide separate compartments for line and low voltages. A screw-down cover shall further restrict access to the high voltage compartment. Overall dimensions shall not exceed 14.25" H X 1.575" W X 4.125" D.

NOTES:

THE EXTERIOR PANEL COVER IS HINGED ON EACH SIDE - THE LOW VOLTAGE SIDE IS LATCHED FOR EASY ACCESS, AND THE LINE VOLTAGE SIDE IS SCREWED DOWN FOR SAFETY.

SPAK 8S 120/277 MODEL SHOWN

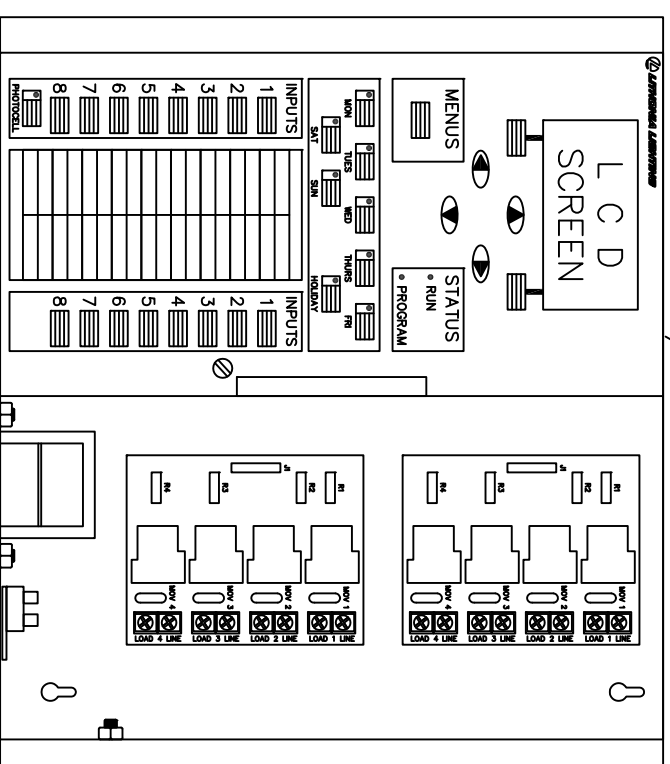

LIGHTING CONTROL PANEL SCHEDULE

LCP NAME: _____			
LOCATION: _____			
POWER CIRCUIT: _____			
RELAY #	CIRCUIT	DESCRIPTION	LV SWITCH/SENSOR SCHEDULE
1			
2			
3			
4			
5			
6			
7			
8			

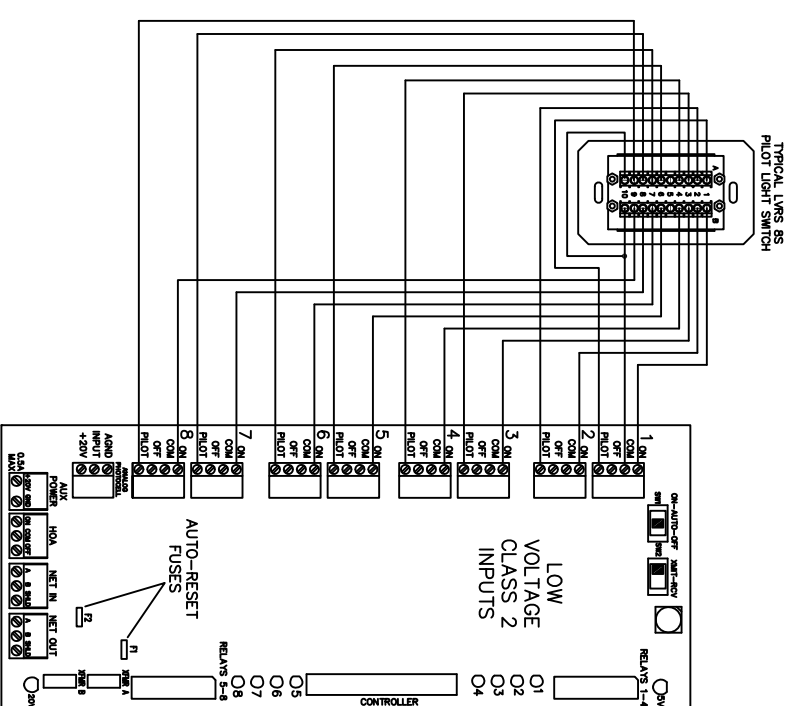
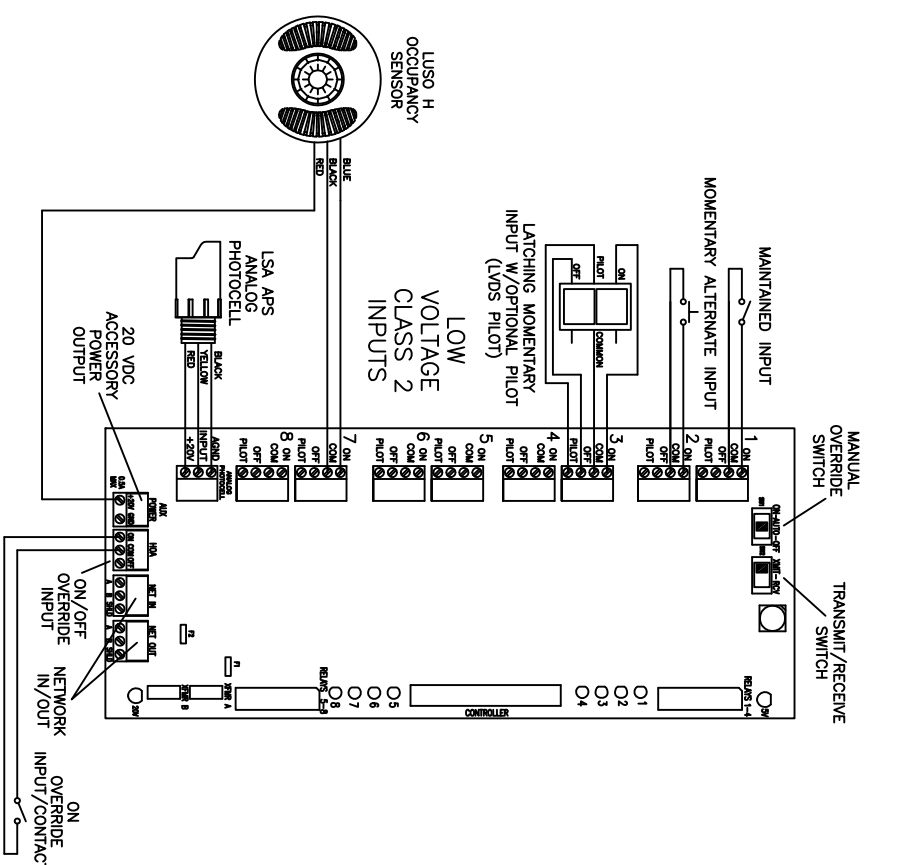

INFORMATION HEREIN CONTAINED IS THE PROPERTY OF SYNERGY LIGHTING CONTROLS AND IS TO BE HELD IN COMPLETE CONFIDENCE. REPRODUCE WITH WRITTEN CONSENT ONLY.

SWITCHPAK LIGHTING CONTROLS



An *Synergy* Brands Company