

Installation Instructions

Universal Relay Power Module - SYPM 8L

**READ AND FOLLOW ALL SAFETY INSTRUCTIONS!
SAVE THESE INSTRUCTIONS AND DELIVER TO OWNER AFTER INSTALLATION**

IMPORTANT SAFETY INSTRUCTIONS

⚠ WARNING

To reduce the risk of death, injury or property damage from fire, electric shock, cuts, abrasions, falling parts, and other hazards:

- Service of the equipment must be performed by qualified service personnel.
- Installation and maintenance must be performed by a person familiar with the construction and operation of this product and any hazards involved. All applicable codes and ordinances must be followed.
- Read this document before installing, servicing, or maintaining this equipment. These instructions do not cover all installation, service, and maintenance situations. If your situation is not covered, or if you do not understand these instructions or additional information is required, contact *Synergy Lighting Controls* at 1-800-533-2719.

⚠ WARNING

Before installing, servicing, or maintaining this equipment, follow these general precautions.

To reduce the risk of electrocution:

- Make sure the equipment is properly grounded.
- Always de-energize any equipment before connecting to, disconnecting from, or servicing the equipment.

To reduce the risk of fire:

- Use supply conductors with a minimum insulation temperature rating as specified.

To reduce the risk of personal injury from cuts, abrasions:

- Wear gloves to prevent cuts or abrasions from sharp edges when removing from carton, handling and maintaining this equipment.
- Do not install damaged equipment.

Synergy Lighting Controls, a division of *Acuity Brands Inc.*, assumes no responsibility for claims arising out of improper or careless installation or handling of this product.

SAVE THESE INSTRUCTIONS

Installation Instructions

Universal Relay Power Module - SYPM 8L

Quick Setup Guide

Module WITHOUT BREAKERS

SEE THE FOLLOWING PAGE FOR MODULES WITH BREAKERS

Refer to the instructions on the following pages for complete details on the steps outlined below.

1 Install the Modules in the Enclosure.

Install the first module in the top position as shown, then install additional modules in the positions below. Make sure the ribbon cable stays at the rear of the enclosure **behind the installed modules**.

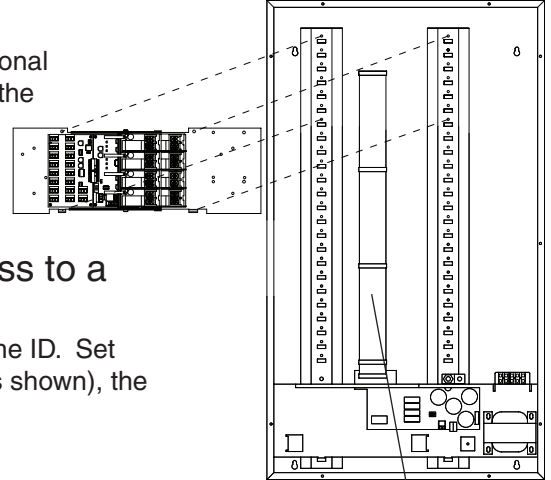

2 Set Each Module Address to a Unique Address

Rotate the address wheel to set the ID. Set the ID of the top module at "1" (as shown), the second at "2" and so on.

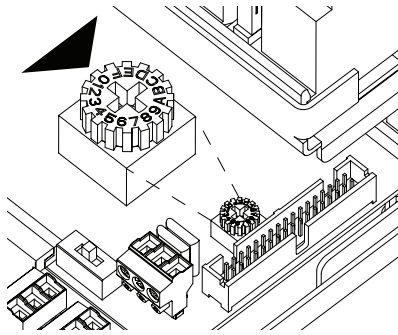

3 Connect the Ribbon Cable to Each Module

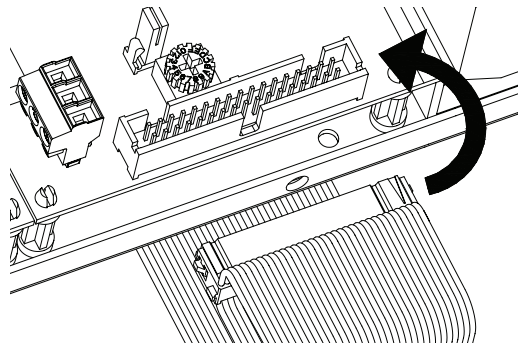

Ribbon Cable

4 Test for Short Circuits in Load Wiring

Test for short circuits in load wiring **PRIOR** to connecting load to output

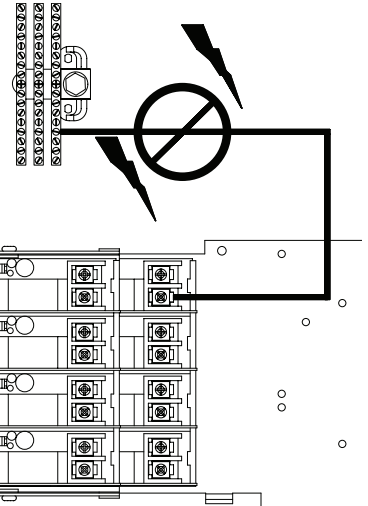

5 Connect Load Wiring as Shown in Figure 1 0-10V Dimming Connections are shown in Figure 2

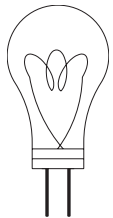

6 Test Power Module Operation

Turn on the cabinet power supply. Use the ON/AUTO/OFF switch to test the module. All module outputs should turn ON when the switch is in the ON (UP) position and turn OFF when the switch is in the OFF (DOWN) position. When testing is complete, return the switch to the AUTO (Center) position. The ON/AUTO/OFF switch **MUST** be in the AUTO position for normal system operation and control from the system controller and low voltage inputs.

7 Connect Any Low Voltage Wiring (If Required) as Shown in Figure 2

Installation Instructions

Universal Relay Power Module - SYPM 8L

Quick Setup Guide

Module WITH BREAKERS

SEE THE PREVIOUS PAGE FOR MODULES WITHOUT BREAKERS

Refer to the instructions on the following pages for complete details on the steps outlined below.

1 Install the Modules in the Enclosure.

Install a neutral bar module in the top position. Install the first relay module in the position directly below the neutral bar as shown, then install additional relay modules in the positions below. Make sure the ribbon cable stays at the rear of the enclosure **behind the installed modules**.

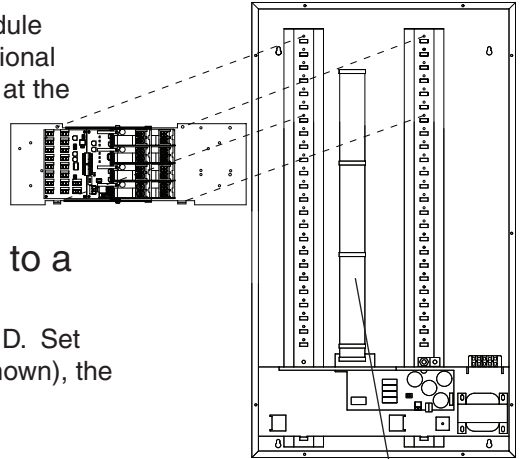

2 Set Each Module Address to a Unique Address

Rotate the address wheel to set the ID. Set the ID of the top module at "1" (as shown), the second at "2" and so on.

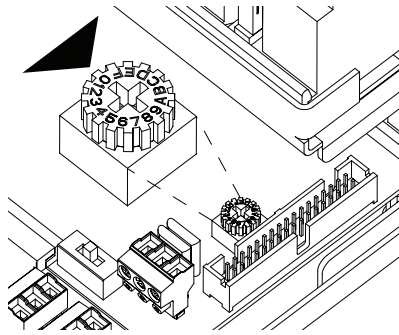

3 Connect the Ribbon Cable to Each Module

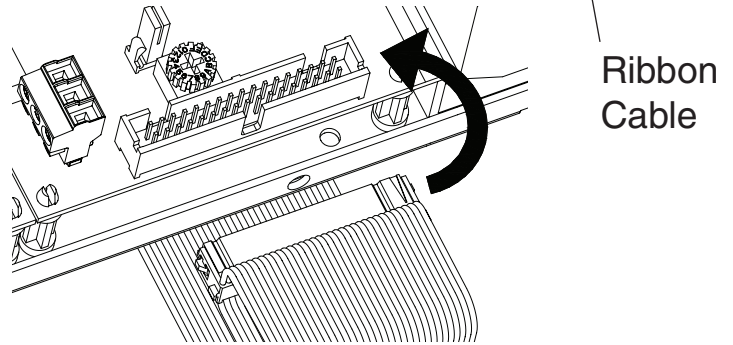

4 Connect the Power Feed Wiring to the Input Lugs

The lugs accept #14 - 2/0 AWG conductors. Use the second lug to tap feed additional modules.

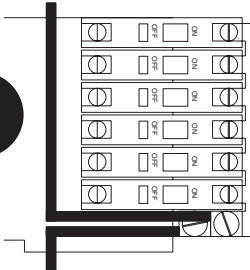

5 Test for Short Circuits in Load Wiring

Test for short circuits in load wiring **PRIOR** to connecting load to output terminals.

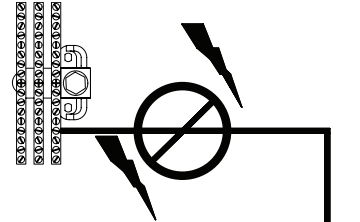

6 Connect Load Wiring as Shown in Figure 1 0-10V Dimming Connections are shown in Figure 2

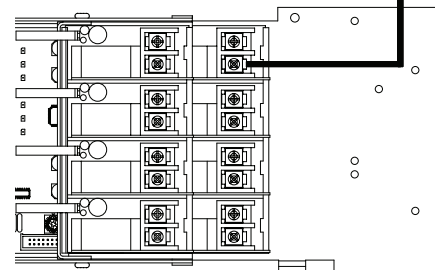

7 Test Power Module Operation

Turn on the cabinet power supply. Turn on all module circuit breakers. Use the ON/AUTO/OFF switch to test the module. All module outputs should turn ON when the switch is in the ON (UP) position and turn OFF when the switch is in the OFF (DOWN) position. When testing is complete, return the switch to the AUTO (Center) position. The ON/AUTO/OFF switch **MUST** be in the AUTO position for normal system operation and control from the system controller and low voltage inputs.

8 Connect Any Low Voltage Wiring (If Required) as Shown in Figure 2

Installation Instructions

Universal Relay Power Module - SYPM 8L

SYPM 8L Power Module Features

The SYPM 8L is a relay power module available in two versions, the SYPM 8L and SYPM 8L DSO (Digital Switching Only). It utilizes 30 Amp mechanically latching relays, which offer increased output capacity and an 18,000 Amp SCCR rating for long, trouble free contact life. During a power loss to the Synergy system, the mechanically latching relay contacts will not change states which is ideal for applications requiring emergency lighting during power outages (emergency power must be supplied by external source). The input terminal blocks for switches, sensors etc are removable for easy conductor termination.

SYPM 8L - (8) relay outputs, (8) 0-10Vdc dimming outputs, (8) dry contact switch inputs, (2) analog (photocell) inputs, (1) remote override input.

SYPM 8L DSO - (8) relay outputs, (1) remote override input.

MANUAL OVERRIDE SWITCH

ON - When the ON position is selected all eight relays and 0-10Vdc dimming outputs will be overridden to the ON state. All commands from low voltage switches, digital remotes, other external inputs or the SYSC controller WILL NOT be executed. To resume responding to commands, the switch must be returned to the AUTO position.

OFF - When the OFF position is selected all eight relays and 0-10Vdc dimming outputs will be overridden to the OFF state. All commands from low voltage switches, digital remotes, other external inputs or the SYSC controller WILL NOT be executed. To resume responding to commands, the switch must be returned to the AUTO position.

AUTO - When the AUTO position is selected all eight relays and 0-10Vdc dimming outputs WILL RESPOND to all commands from low voltage switches, digital remotes, other external inputs and the SYSC controller. **The AUTO position is the standard position for this switch during normal operation.**

MANUAL OVERRIDE INPUT

This input functions identically to the manual override switch (described above), but uses external dry contacts (AV, BAS systems etc) to trigger the three possible states (ON, OFF or AUTO).

SWITCH INPUTS

The SYPM 8L has eight inputs for switches, sensors, contact closures and other external devices. The terminal and their functions are:

DIM - Provides the 0-10Vdc signal output to dim 4 wire fluorescent ballasts or LED drivers.

PLT - Provides power to the status light on a dry contact switch.

COM - The common terminal for 0-10Vdc dimming and pilot lamp(s). Commons for pilot lamps and 0-10V dimming can be connected in the same terminal if needed.

ON - Terminal for ON dry contact switch connections.

24V - Common terminal for dry contact switch connections.

OFF - Terminal for OFF dry contact switch connections.

MANUAL OVERRIDE SWITCH

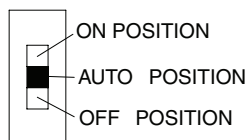

REMOTE OVERRIDE TERMINAL BLOCK

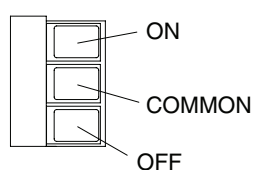

Manual Override Details

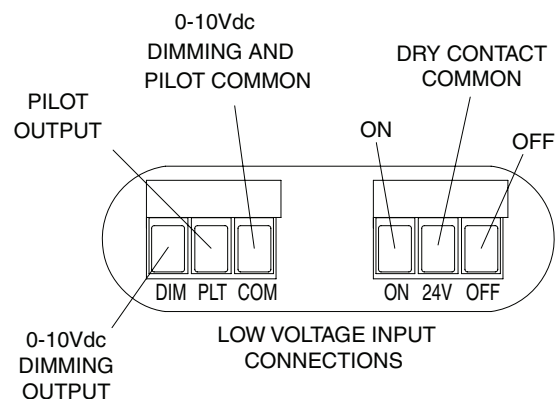

Dry Contact Switch Input Details

Installation Instructions

Universal Relay Power Module - SYPM 8L

Before You Start

1. Always disconnect all power.
2. Install in accordance with the National Electrical Code and any other codes which may apply.
3. Use only as intended and at the listed voltage.

Important Module Installation Notes

1. Install power modules in cabinet starting at the top. **Plug ribbon cable into each module before installing the next module. Ribbon cable installs behind modules.**
2. SYPM 8L relays are rated for:
 - 30A@277V Ballast
 - 20A@120V Tungsten
 - 20A@347V Ballast
 - 18K Amp SCCR rating @277 VACVerify load type is compatible with these maximum ratings.
3. Test branch circuits for short circuits **prior** to energizing module.
4. Module relay output terminal specification:
(1) #8 - #14 AWG or (2) #8 - #14 AWG maximum.
7. **DO NOT** connect multi-pole circuits or loads to these relays. Equipment warranty void if multi-pole loads are controlled directly. Use Synergy 2, 3 or 4 pole accessory relays (SYA 2POLE/3POLE/4POLE) or external contactors only.
8. The 0-10 VDC ballast control output connections are Class 2 circuits and should be installed in accordance with the National Electric Code and any local codes which may apply. For specific information on conductor routing for your application consult the ballast manufacturer's recommendations.
9. A minimum of two and maximum of fifty 0-10VDC ballasts can be connected to one 0-10VDC ballast output.

Installation Instructions

Universal Relay Power Module - SYPM 8L

Module Installation and Wiring

1. **MOUNT TOP MODULE**
Starting at the TOP of the cabinet, mount the module by setting the bottom tabs in the slots at the back of the cabinet then securing the top with the screws provided.
2. **SET MODULE ID AND CONNECT RIBBON CABLE** Rotate the relay card ID switch to the address 1 position. (See Figure 1) Plug the male connector on the ribbon cable into the female socket on the relay module. Ribbon cable installs behind the modules.
3. Repeat steps 1 & 2 for additional modules, incrementing the relay card ID switches by 1 from the top of the cabinet down.
4. **PROVIDE PRIMARY POWER WIRING & BRANCH CIRCUIT CONNECTION**
Modules without breakers:
Connect the terminal labeled LINE on each relay to an appropriately sized, single pole branch breaker. A single branch breaker can be connected to multiple LINE terminals if required. Make load wiring connections per Figure 1.
Modules with breakers:
Connect each module input lug to an appropriately sized conductor. Use the module's feed through lug to connect additional modules to an input circuit on the same phase. See Figure 1 for load connection details and Figures 3 and 4 for typical feed wiring details.
Torque connections to 16 inch-lbs.
Refer to Synergy supplied As-Built drawings for more details.
TEST FOR SHORT CIRCUITS PRIOR TO ENERGIZING MODULE.
5. **FOR 0-10VDC DIMMING APPLICATIONS**
0-10V ballast control wires (violet and gray) connect to the DIM and COM terminals on the removable terminal blocks on the Input/Output card. The violet wire connects to DIM, the gray connects to COM. See Figure 2 for more details.
A minimum of two and maximum of fifty 0-10VDC ballasts can be connected to one 0-10VDC ballast output.
6. **CONNECT LOW VOLTAGE INPUT WIRING**
Inputs from switches, sensors, contact closures and other external devices terminate to the ON, OFF, PLT, COM, 24V and AIN terminals in the removable terminal blocks on the Input/Output card. (See Figure 2 for details)
Refer to Synergy supplied As Built drawings, accessory instructions or project specifications for details.
7. **START-UP POWER MODULES TO ALLOW MANUAL LIGHTING CONTROL**
Following this procedure step by step will reduce the chance of damage due to relay closing on a short circuit. Module warranty void if relay closes on a short circuit.
 1. Turn off all Branch Breakers.
 2. Verify "MANUAL OVERRIDE SWITCH" is in the ON position. (See Figure 1)
 3. Turn on circuit breaker for the enclosure power supply.
 4. Turn on branch breakers. Use the manual override switch for convenient on/off override.
8. **POWER MODULE CONFIGURATION**
The power modules are fully programmable with the addition of the SYSC system controller. Refer to the SYSC system controller installation instructions and Synergy Operation and Programming Manual for more information.

Installation Instructions

Universal Relay Power Module - SYPM 8L

Troubleshooting Procedures

SWITCH INPUTS NOT WORKING:

1. Remove the terminal block of the input being tested.
2. The current status of each input can be viewed at the SYSC controller. On the controller press START...SEARCHING...STATUS...INPUTS...MODULES
Status for each input is displayed by module. For example, all inputs for module 2 are displayed on one screen, numbered as 02xx, where xx is the input number.
3. Use the UP and DOWN arrow keys to move to the desired module input screen, the current status for each input will be displayed. A * indicates the input is ON, a . indicates the input is OFF. Using a suitable jumper (wire, screwdriver, etc) short between the ON and 24V terminal, the input status should show * (ON). Short between OFF and 24V, the input status should show . (OFF).
4. If this test is successful, the switch inputs are working properly. Reinstall the input terminal block and test the switch. If the switch input is still not working, either the wiring to the switch(es) and/or the switch(es) themselves are defective. Correct as required.

THE RELAYS OR 0-10V OUTPUTS ARE NOT FUNCTIONING. FOLLOW THESE STEPS:

1. Verify the correct voltage is present between the LINE terminal and the NEUTRAL BUSS.
2. Verify the cabinet power supply LEDs are on and the RIBBON CABLE is properly connected to the power supply and the module.
3. Verify the module CIRCUIT BREAKERS are in the ON position (if applicable).
4. Verify voltage is present on the LOAD terminal and/or the output of the CIRCUIT BREAKERS.

5. Move the MANUAL OVERRIDE SWITCH on the relay module to the "ON" position. All loads and RELAY OUTPUT STATUS LEDs should turn on.

FOR 0-10VDC BALLASTS ONLY:

6. Verify the DC voltage between the DIM and COM terminals is approximately 10VDC when the MANUAL OVERRIDE SWITCH is in the ON position. Verify the voltage between the DIM and COM terminals is approximately 0.7VDC when the MANUAL OVERRIDE SWITCH is in the OFF position.
7. Switch the MANUAL OVERRIDE SWITCH on the relay module to "AUTO". Verify the voltage between the DIM and COM terminals varies between 0 and 10VDC while the outputs are being raised and lowered using the controller, control stations or other input devices.

A basic test for 0-10VDC dimming ballast operation is to connect the violet and grey wires together at the ballast (ballast must have line voltage power applied during this test) The lamps should dim to the lowest dimmed level. Then disconnect the violet and grey wires, the lamps should go to full output. If this test IS NOT successful, the ballast and/or control wiring is faulty. Consult the ballast manufacturer if additional troubleshooting or information is required.

FOR ALL LOAD TYPES:

8. If the loads switch on/off using the manual override switch but do not respond to the controller, check the system programming. See the Synergy Operation Manual for programming instructions.

If after performing the above tests one or more circuits still do not operate correctly, contact Synergy Lighting Controls Technical Service department, Monday - Friday, at 800-533-2719.

Visit Synergy Lighting Controls on the internet at <http://www.synergylightingcontrols.com> for further information on products, technical data or installation instructions.

Warranty

Synergy Lighting Controls warrants all equipment to be free from defect in manufacturing under normal and proper storage, installation, and operation for a period of one (1) year. Our guarantee liability extends only to the repair or replacement of the defective part and no labor charges for correction of the defect by repair or replacement will be honored by Synergy Lighting Controls unless prior written authorization has been granted by our Customer Service Department.

Installation Instructions

Universal Relay Power Module - SYPM 8L

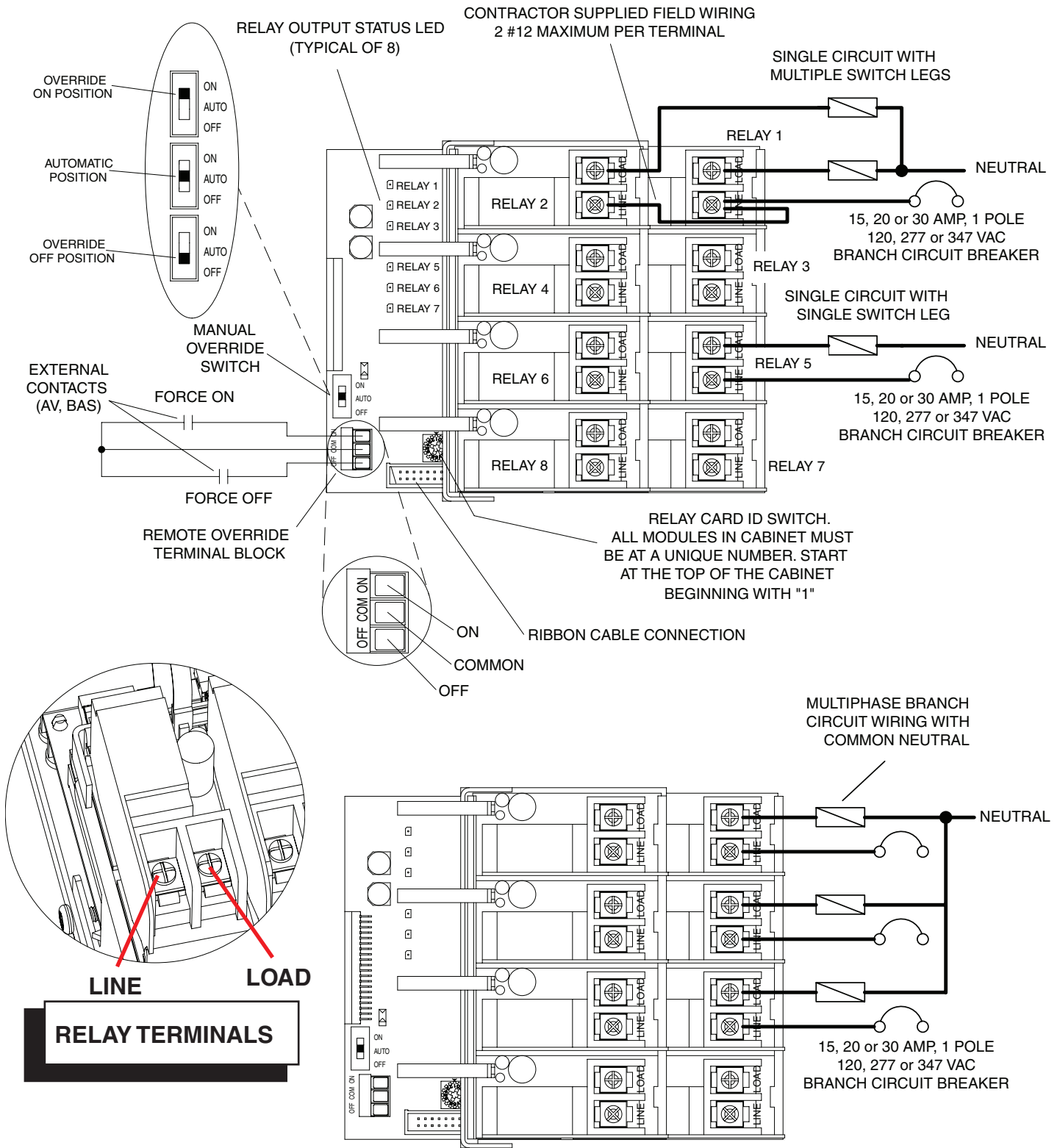

Figure 1 - SYPM 8L DSO (No Switch Inputs) Switching Only Wiring Detail

Installation Instructions

Universal Relay Power Module - SYPM 8L

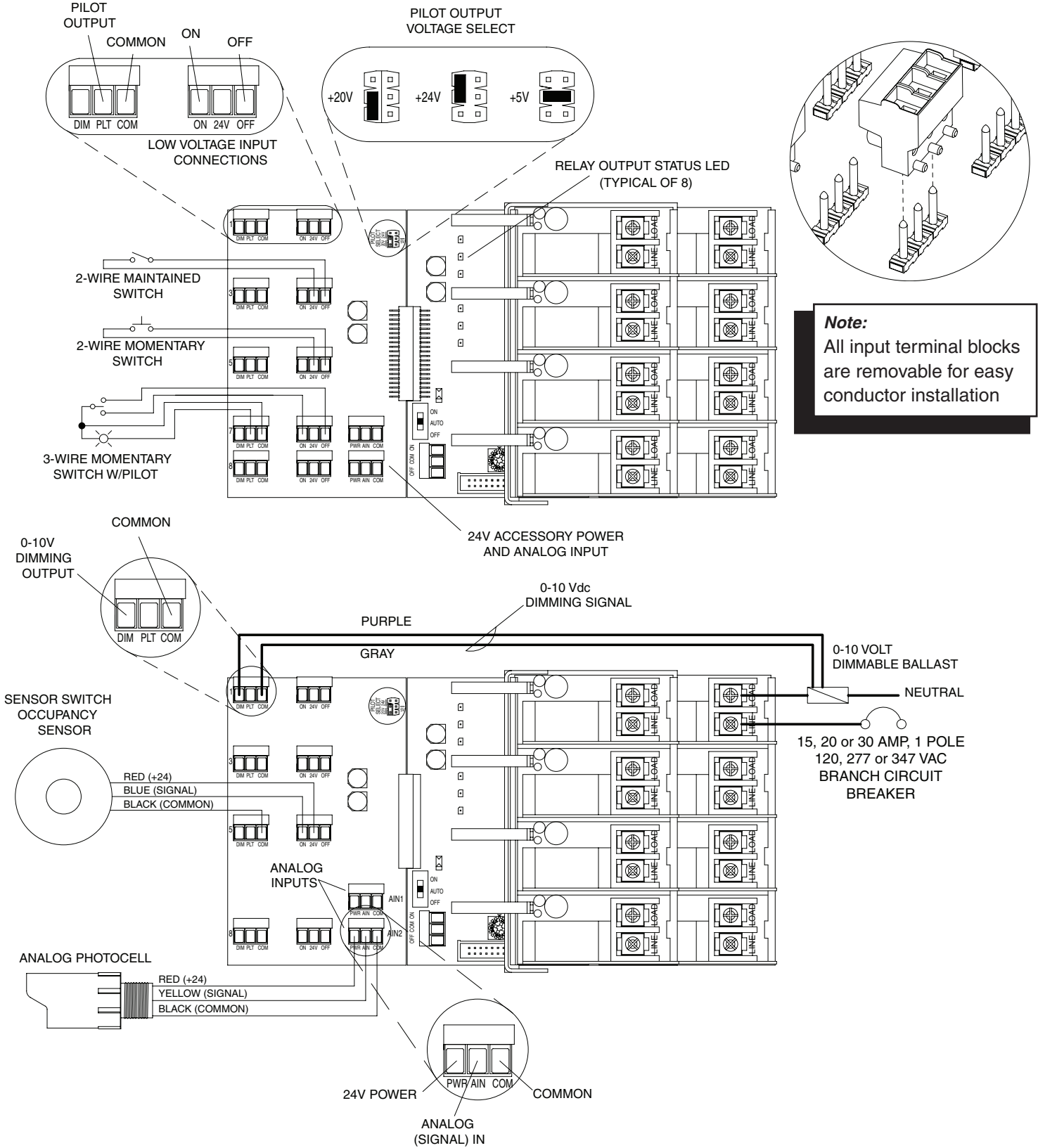
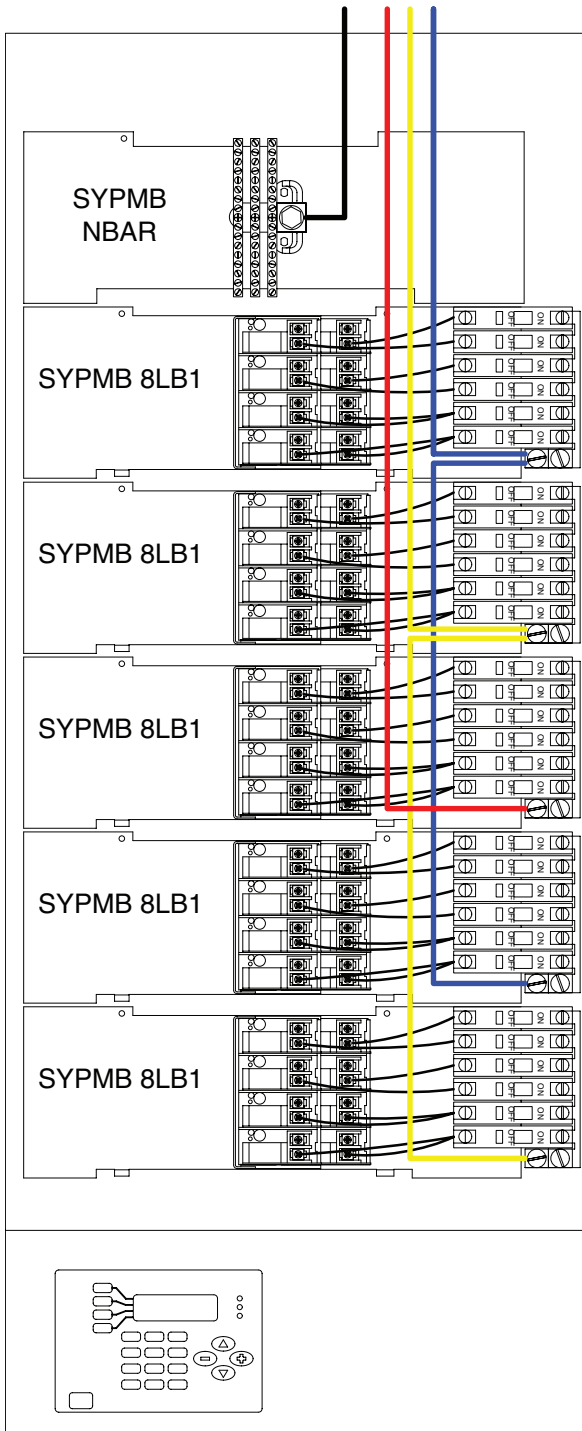

Figure 2 - SYPM 8L Switch Inputs and 0-10Vdc Dimming Wiring Detail

Installation Instructions

Universal Relay Power Module - SYPM 8L

Three Phase Four Wire Main Feed Details



**Figure 3 - Large Enclosure Module Population
Modules w/Breakers and Neutral Bar**

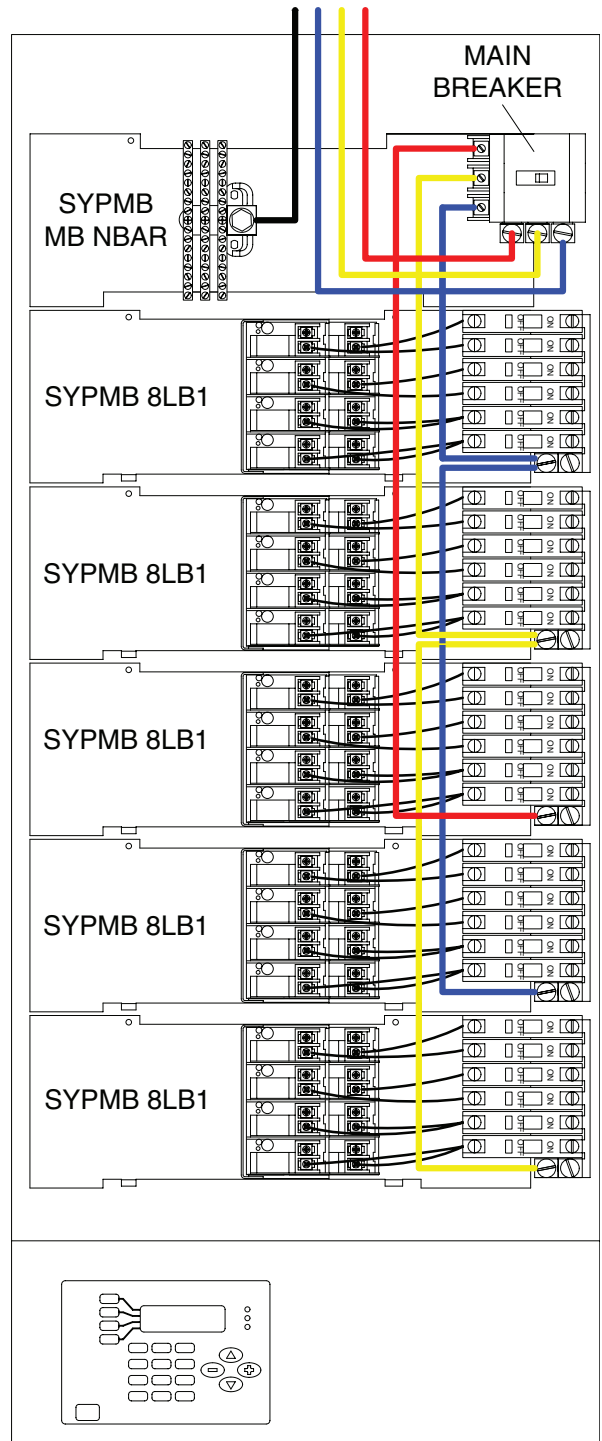

**Figure 4 - Large Enclosure Module Population
Modules w/Breakers, Neutral Bar and Main Breaker**