

**READ AND FOLLOW ALL SAFETY INSTRUCTIONS!
SAVE THESE INSTRUCTIONS AND DELIVER TO OWNER AFTER INSTALLATION**

IMPORTANT SAFETY INSTRUCTIONS

⚠WARNING

To reduce the risk of death, injury or property damage from fire, electric shock, cuts, abrasions, falling parts, and other hazards:

- Service of the equipment must be performed by qualified service personnel.
- Installation and maintenance must be performed by a person familiar with the construction and operation of this product and any hazards involved. All applicable codes and ordinances must be followed.
- Read this document before installing, servicing, or maintaining this equipment. These instructions do not cover all installation, service, and maintenance situations. If your situation is not covered, or if you do not understand these instructions or additional information is required, contact *Synergy Lighting Controls*.

⚠WARNING

Before installing, servicing, or maintaining this equipment, follow these general precautions.

To reduce the risk of electrocution:

- Make sure the equipment is properly grounded.
- Always de-energize any equipment before connecting to, disconnecting from, or servicing the equipment.

To reduce the risk of fire:

- Use supply conductors with a minimum installation temperature rating as specified.

To reduce the risk of personal injury from cuts, abrasions:

- Wear gloves to prevent cuts or abrasions from sharp edges when removing from carton, handling and maintaining this equipment.
- Do not install a damaged equipment.

Synergy Lighting Controls, a division of *Acuity Brands Inc.*, assumes no responsibility for claims arising out of improper or careless installation or handling of this product.

SAVE THESE INSTRUCTIONS

Installation Instructions

SwitchPak - SPAK



Before You Start

1. Always disconnect all power.
2. Install in accordance with the National Electrical Code and any other codes which may apply.
3. Use only as intended and at the listed voltage.
4. All installation and service must be performed by qualified personnel or service technicians.
5. Do not install conduit where "No Conduit Entry" is shown in *Figure 1*.
6. Do not discard these instructions, this document is a reference for installation, programming, operation, and maintenance of the system.
7. All installation and wiring information contained herein is based on industry-accepted standards and practices. This information is not meant to conflict with or overrule any applicable codes or ordinances. If any conflicts exist, please contact Synergy Lighting Controls before proceeding with the installation.
8. Document all wiring, device terminations and locations. This information will be necessary to correctly configure the system and perform the system start up .
9. USE EXTREME CAUTION WHEN PERFORMING MAINTENANCE ON THIS EQUIPMENT. HIGH VOLTAGE IS PRESENT INSIDE THE ENCLOSURE! Failure to follow any or all warnings and proper safety procedures can cause severe injury or death, and/or damage to the equipment.

Install Cabinet

1. Mount the cabinet using the four holes provided in the back of the enclosure. Refer to *Figure 2* for dimensions.
2. Choose the desired location for line voltage and low voltage conductor entry in the cabinet. DO NOT install conduit where NO CONDUIT ENTRY is shown in *Figure 1*.
3. **ALL LINE VOLTAGE** conductors **must** enter the cabinet on the right side (when facing) of the enclosure, in the area shown in *Figure 1*.
4. **ALL LOW VOLTAGE** conductors **must** enter the cabinet on the left side (when facing) of the enclosure, in the area shown in *Figure 1*.
5. Remove **ALL** metal shavings and excess contaminants from the enclosure **before** applying power to the cabinet.

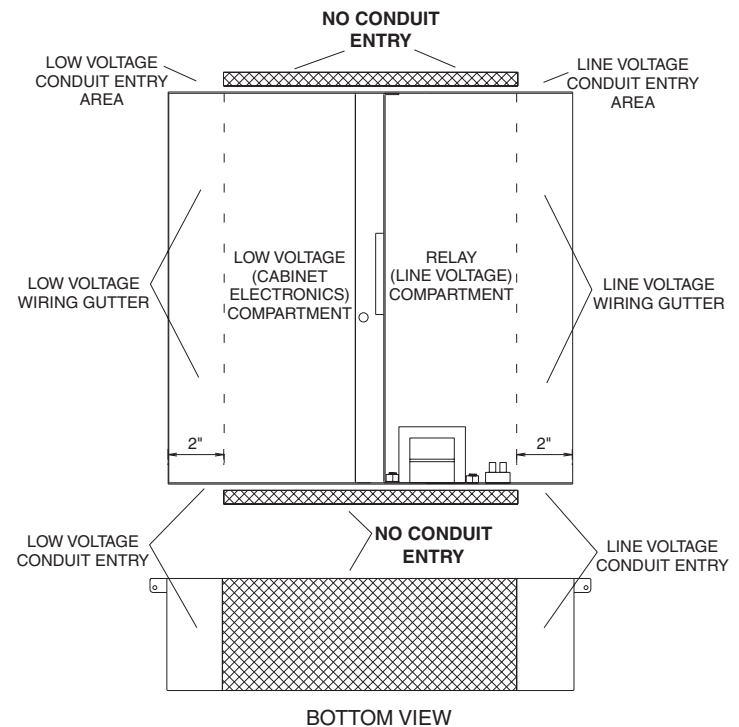

Figure 1 - Conduit and Cable Entry

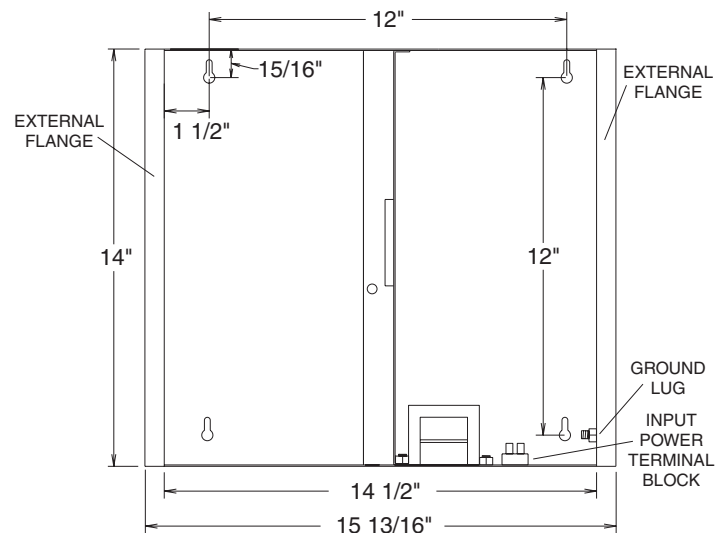

Figure 2 - Cabinet Dimensions

Semi-recessed mounting option:
Opening should be 14 5/8" wide, 14 1/16" high, and requires 3 3/8" wall depth minimum.

Connect Power Supply Input

1. Use conductors with minimum 90°C insulation rating.
2. Connect a dedicated 15 or 20 amp branch circuit to the power supply input. The power supply input can be connected to either 120 or 277 VAC, 60 Hertz. The power supply terminal block label shows the connection positions for each voltage, see *Figure 3* for details.
3. Attach a spade (fork) or ring terminal to a suitably sized ground conductor, then connect the ground to the grounding stud in the lower right side of the enclosure. See *Figure 2* for details.

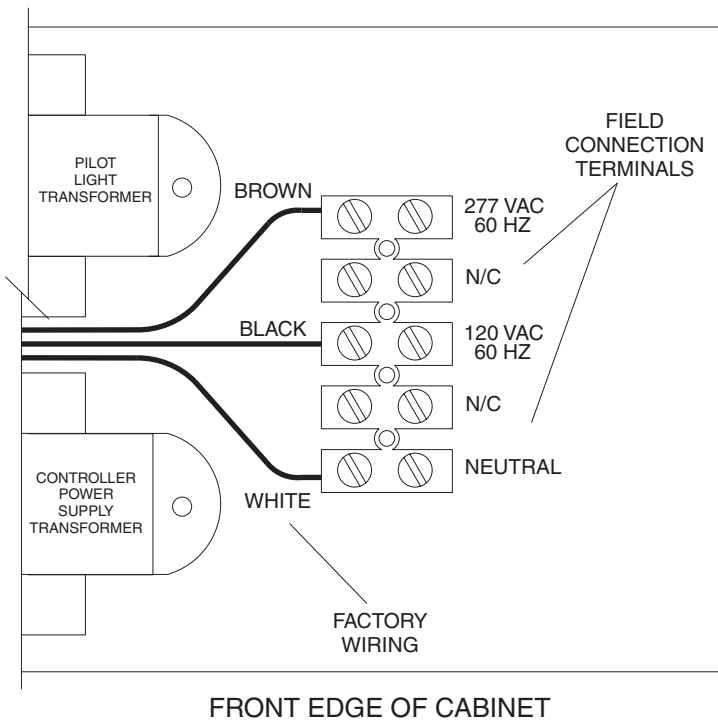

Figure 3 - Power Supply Connections

Important Relay Connection Notes

1. Test branch circuits for short circuits **prior** to energizing the SwitchPak.
2. Relay terminal block specification (1) #10, #12, #14 AWG or (2) #12, #14 AWG maximum.
3. **DO NOT** connect 2 pole circuits or loads to SwitchPak single-pole relays, this will void the equipment warranty. For 2 pole or 30 Amp loads use the optional SwitchPak 2 pole, 30 Amp relays.

Connect Loads - 8 Single Pole

1. Connect a 120 or 277 volt, 20 amp maximum, branch circuit breaker to the output terminal block position labeled LINE.
2. Connect the load to the output terminal block position labeled LOAD. See *Figure 4* for details.

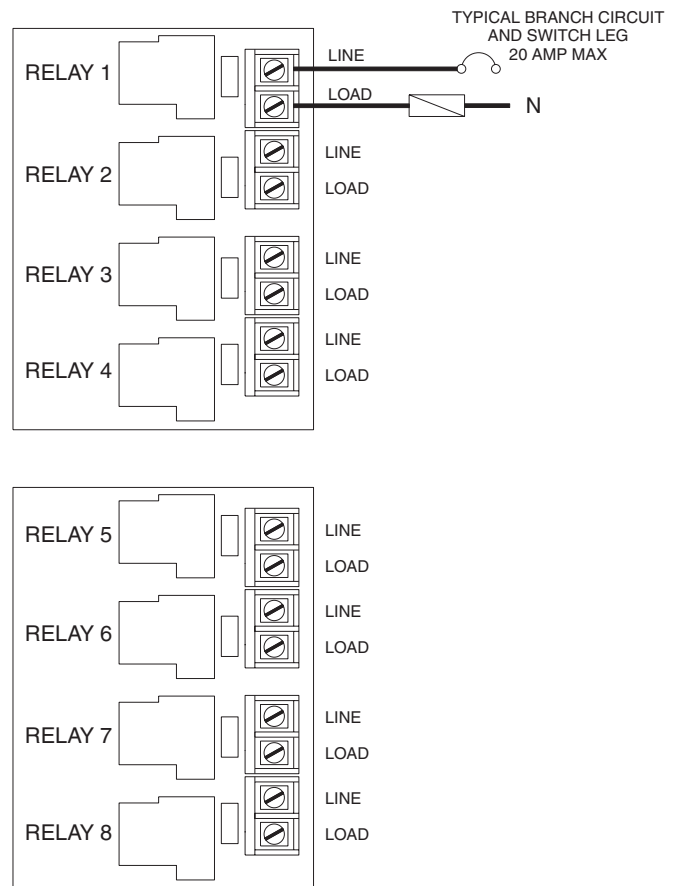

Figure 4 - Load Connections 8S (8 Single Pole)

Connect Loads - 4 Single Pole, 2 Double Pole

Single Pole Relays:

1. Connect a 120 or 277 volt, 20 amp maximum, branch circuit breaker to the output terminal block position labeled LINE.
2. Connect a single pole load to the output terminal block position labeled LOAD. See *Figure 5* for details.

Note: Factory wiring configures the 4 single pole relay outputs to correspond to RELAY buttons 1- 4.

Double Pole Relays:

1. Connect the 2 pole relay card CONTROL POWER INPUT to a 120 or 277 volt circuit, typically the same circuit connected to the cabinet power supply.
2. Connect a 120 or 277 volt, 30 amp maximum, 2 pole branch circuit breaker to the 2 pole relay terminal positions labeled LINE.

3. Connect a 2 pole load to the 2 pole relay terminal positions labeled LOAD. See *Figure 5* for details.

Note: Factory wiring configures the 2 double pole relay outputs to correspond to RELAY buttons 5 and 6.

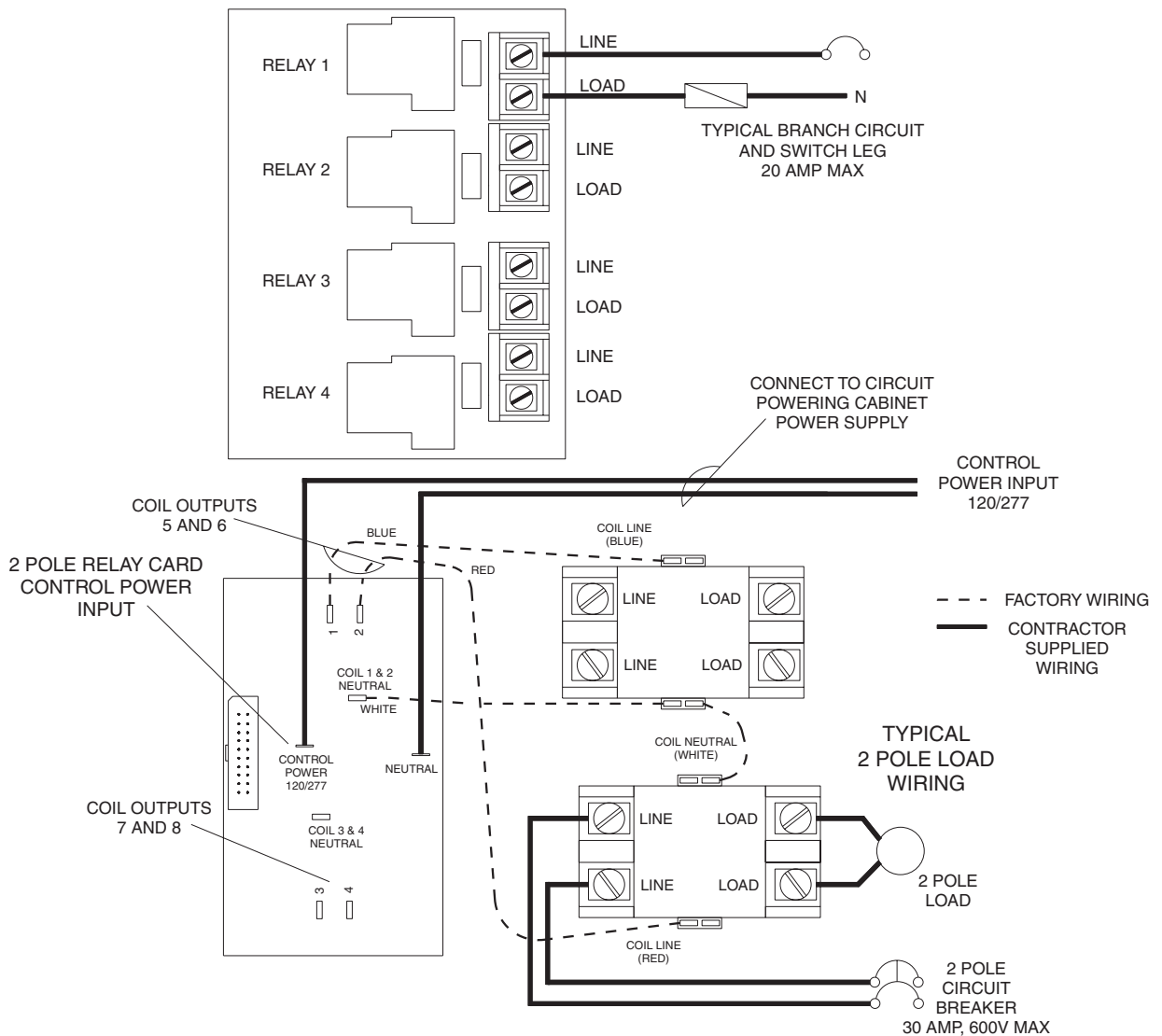

Figure 5 - Load Connections 4S 2D (4 Single Pole, 2 Double Pole)

Connect Loads - 4 Double Pole

Double Pole Relays:

1. Connect the 2 pole relay card CONTROL POWER INPUT to a 120 or 277 volt circuit, typically the same circuit connected to the cabinet power supply.
2. Connect a 120 or 277 volt, 30 amp maximum, 2 pole branch circuit breaker to the 2 pole relay terminal positions labeled LINE.
3. Connect a 2 pole load to the 2 pole relay terminal positions labeled LOAD. See *Figure 6* for details.

Note: Factory wiring configures the 4 double pole relay outputs to correspond to RELAY buttons 1 - 4.

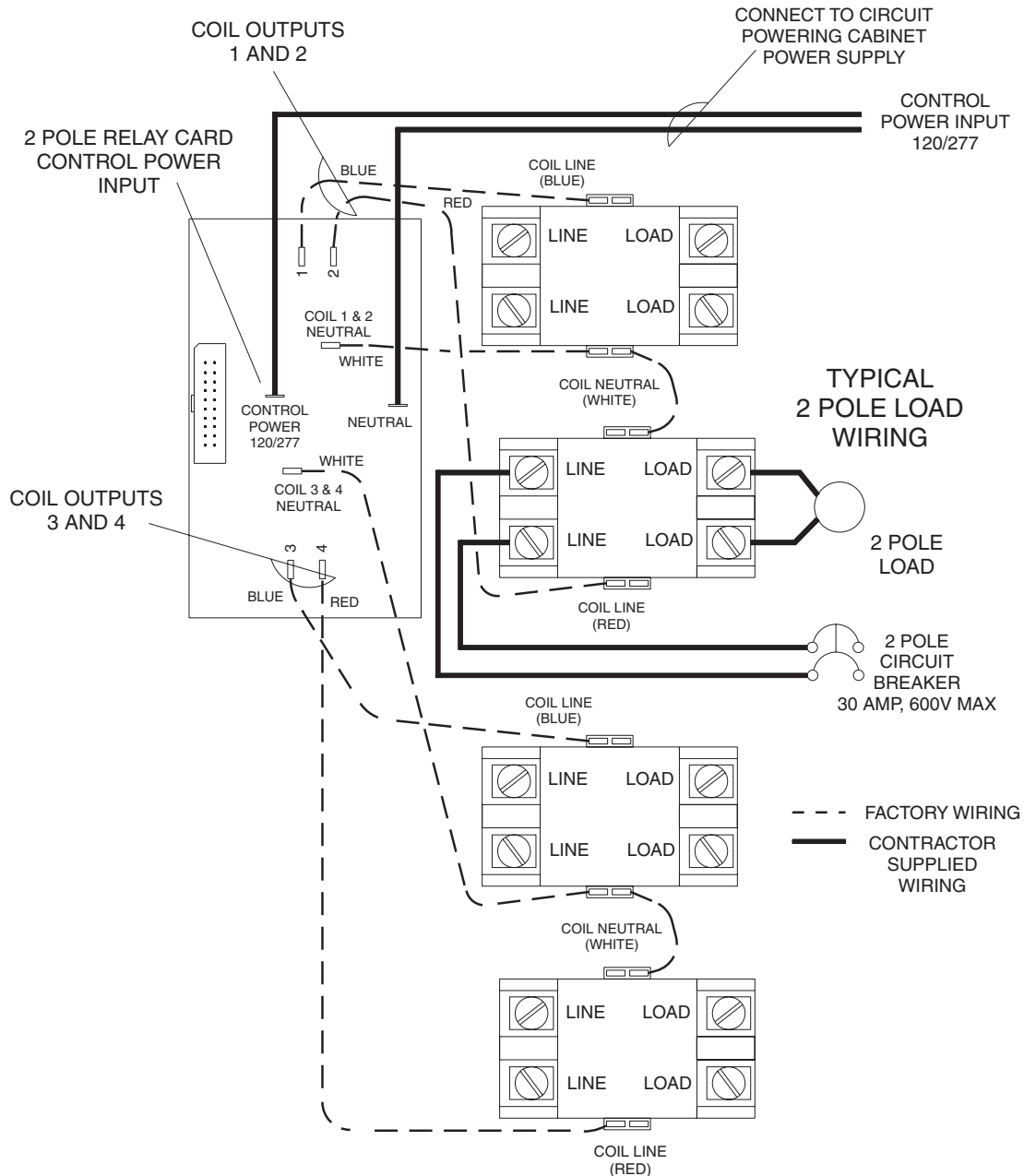

Figure 6 - Load Connections 4D (4 Double Pole)

Make Low Voltage Connections

1. If required, connect low voltage switches or other dry contact closure devices to the switch inputs. See *Figure 7* for typical connection details.
2. If required, connect an analog photocell to the analog photocell input. See *Figure 7* for typical connection details.
3. If required, connect a low voltage occupancy sensor to a switch input. See *Figure 7* for typical connection details.
4. The ON/OFF override input can be connected to a normal sense relay (RRU SPDT), or other dry contact closure devices and switches to provide override control of all relays. All relays (excluding any programmed as DISABLED) will be overridden when using this input. See *Figure 7* for typical connection details.

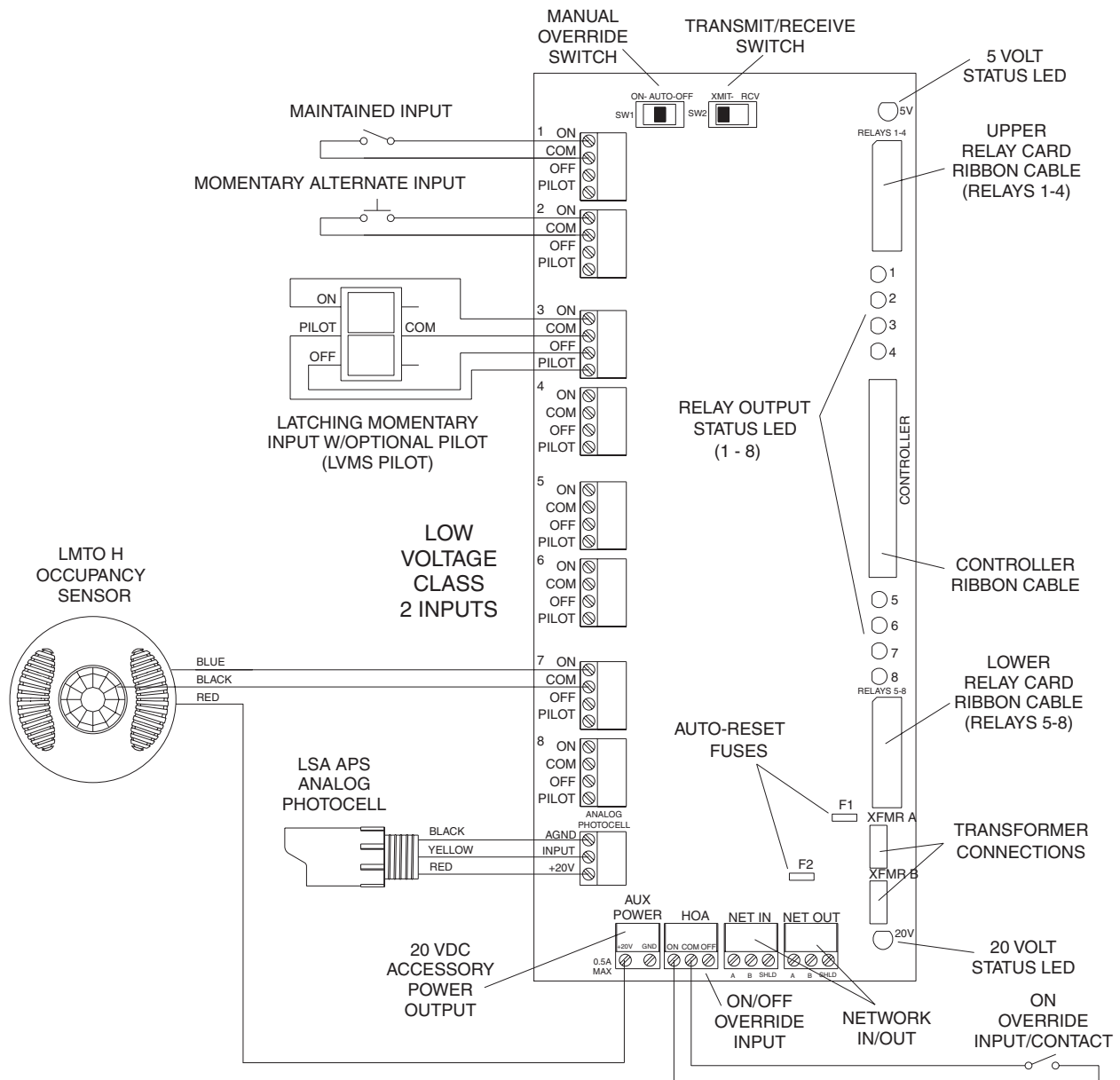

Figure 7 - Low Voltage Connections

System Remote Network Connections

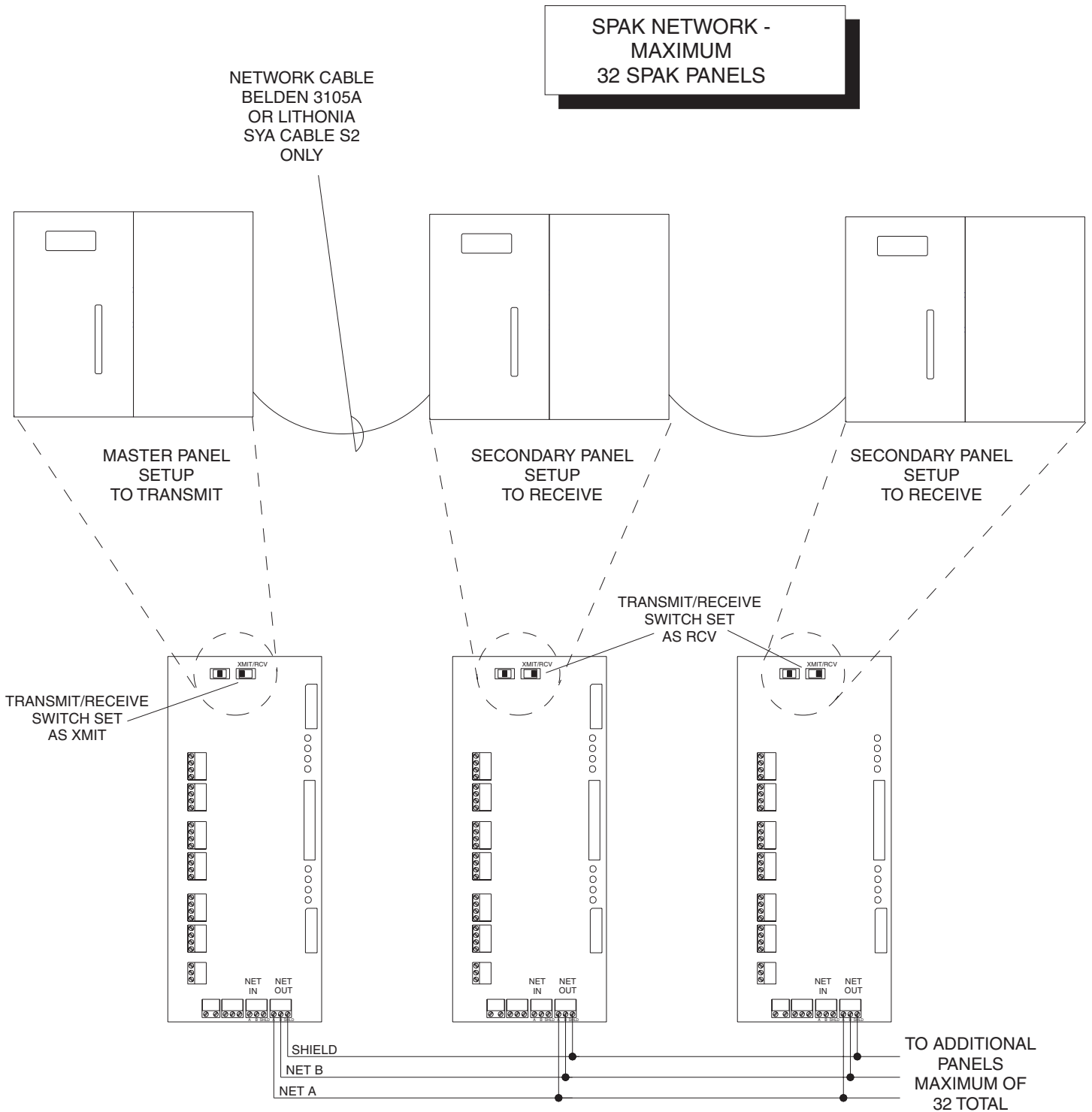

Figure 8 - SPAK network connections

Troubleshooting Procedures

SYMPTOM: OUTPUTS (RELAYS) DO NOT SWITCH ON OR OFF

Check the following:

1. Verify the 5 volt and 20 volt GREEN (STATUS) LEDs on the power supply card are on. (See *Figure 7 for LED locations*). If both LEDs are on, proceed to STEP 2. If either LED is not on, verify the correct voltage is present on the INPUT POWER TERMINAL BLOCK. Verify the wires connecting the input transformers to the CONTROLLER CARD (purple wires) are connected properly. (See *Figure 7*) If these conditions are correct and either or both LEDs are still not on, contact Lithonia Controls Technical Support for more information. (See contact information below)
2. Verify the correct voltage is present on the LINE side of the RELAY TERMINAL BLOCK. If the correct voltage is present and the outputs still don't function correctly, proceed to STEP 3.
3. Verify both the UPPER and LOWER RELAY CARD RIBBON CABLES are properly connected to the POWER SUPPLY and RELAY CARD SOCKETS. (See *Figure 7*) If both are properly connected and the outputs still don't function correctly, proceed to STEP 4.
4. Switch the MANUAL OVERRIDE SWITCH on the POWER SUPPLY CARD to the "ON" position. (See *Figure 7 for switch location*) All loads which are programmed as NORMALLY OPEN (default) and the corresponding RELAY OUTPUT STATUS LEDs should turn on.
5. Switch the MANUAL OVERRIDE SWITCH on the POWER SUPPLY CARD to "AUTO". Use the RELAY BUTTON(S) on the front panel to switch individual relays ON/OFF. Observe the RELAY OUTPUT STATUS LEDs on the POWER SUPPLY CARD. The LEDs for all relays which are NOT programmed as DISABLED should indicate ON/OFF as the RELAY BUTTON(S) are being pressed. Also, an audible clicking should be heard as the relays switch.

If after performing the above tests the panel still does not function correctly, contact Synergy Lighting Controls Technical Support. (See contact information below)

SYMPTOM: THE INPUT BUTTON(S) ARE OPERATING THE WRONG RELAY(S)

1. Check Programming. The RELAY BUTTON LED for each relay controlled by an INPUT BUTTON will light when switched on by the input. If a programming error is suspected, consult the SwitchPak Operation and Maintenance Manual for detailed programming information.

Contact Synergy Lighting Controls Technical Support at 800-533-2719. Synergy Lighting Controls Technical Support is available from 8:00 a.m. to 5:00 p.m. EST Monday through Friday for phone consultation.

Visit Synergy Lighting Controls on the internet at <http://www.synergylightingcontrols.com> for additional information on products, technical data and installation instructions.

Warranty

Synergy Lighting Controls warrants SPAK equipment to be free from defects in manufacturing under normal and proper storage, installation and operation for a period of one (3) years. Our guarantee liability extends only to the repair or replacement of the defective part and no labor charges for correction of the defect by repair or replacement will be honored by Synergy Lighting Controls unless prior written authorization has been granted by our Customer Service Department.