

Commercial Channel

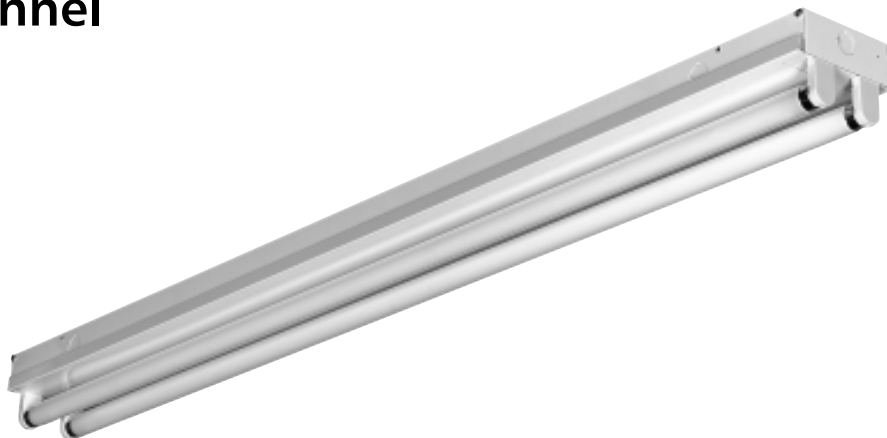

APPLICATIONS

Designed to provide lighting for institutional, industrial, and commercial environments.

FEATURES

This commercial channel is available in 4' and 8' nominal lengths.

Ballast cover secured by captive quarter-turn fasteners for easy access to wireway.

High-gloss, baked white enamel finish.

Combination endplate/channel connector furnished with each fixture.

SPECIFICATIONS

HOUSING: Formed from cold rolled, pre-painted steel. Five stage iron-phosphate pretreatment ensures superior paint adhesion and rust resistance. Painted parts finished with high-gloss, baked white enamel.

MOUNTING: The HSM series fixture is suitable for surface mounting, as well as for suspended mounting with stems, threaded rods, or chains.

LAMP HOLDERS: T8 lamps are secured with locking lampholders.

PHOTOMETRY

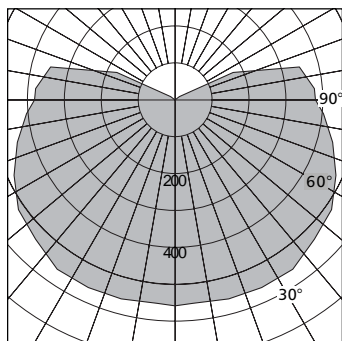

HSMS04DSNNNO40
 Test #HL5049
 Fixture Efficiency: 93.3%
 SC Across: 1.5, SC Along: 1.3

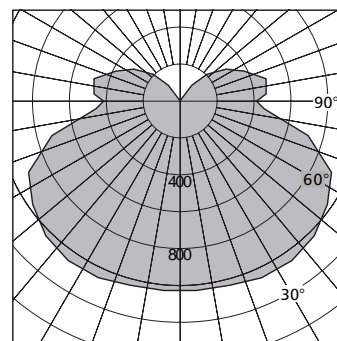

HSMS04DSNNNO42
 Test #HL5181
 Fixture Efficiency: 92.8%
 SC Across: 1.6, SC Along: 1.3

