

FINIALS



CLEAR
(Acrylic)



STANDARD
(Cast Aluminum)

**Maximum Weight - 5.5 lbs.
Effective Projected
Area - .24 sq. ft.**

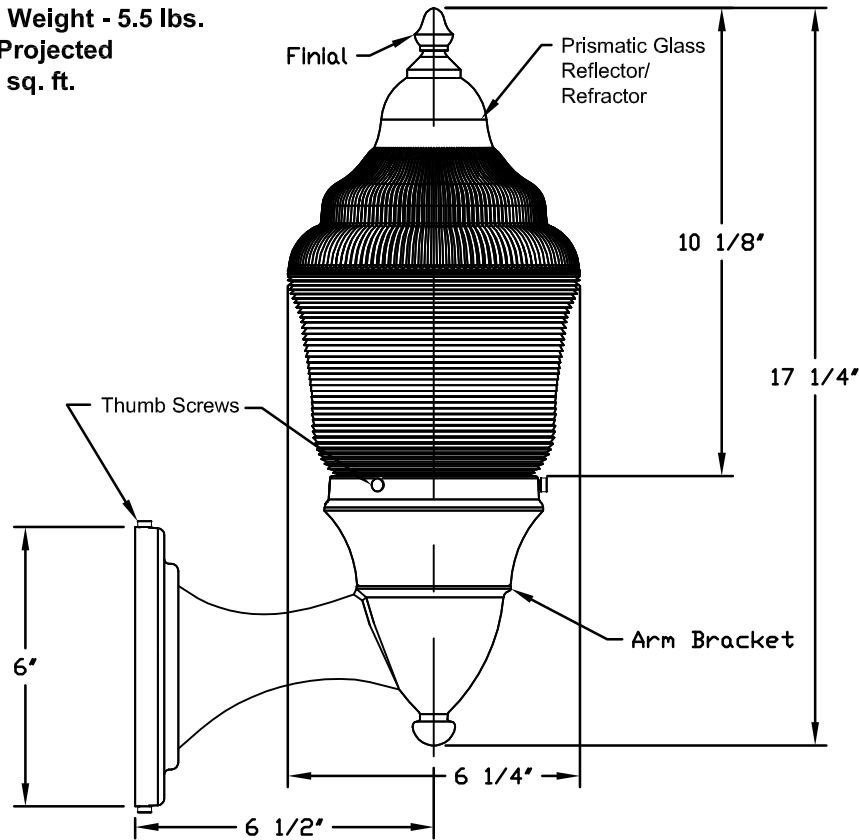

**GranVille®
Micro**

**Architectural
Outdoor**

MGM75DIN12SB5

MGM

75DIN

12

S

B

5

LUMINAIRE
MGM = Granville
Micro

Source and Wattage
75DIN = 75W INCANDESCENT

Voltage
12 = 120 VOLT

Arm Bracket
S = Standard
Arm Bracket

Housing Color
A = As Specified
B = Black

Optics
5 = Symmetric



ORDERING INFORMATION:

Specifications

GENERAL DESCRIPTION

The luminaire consists of two main components, an electrical housing, and a prismatic glass optical assembly.

OPTICAL ASSEMBLY

The optical assembly is a precisely molded soda lime glass reflector and refractor with or without finial. The upper portion of this system incorporates a series of reflecting prisms that redirects the upward light into the controlling refractor while allowing a soft uplight component to define the traditional acorn shape of the luminaire. The lower portion uses precisely molded refracting prisms to control the distribution of light to maximize uniformity.

ARM BRACKET

The arm bracket contains an electrical socket and is designed for a maximum of 75 W lamp. The housing is cast of aluminum. The optical assembly is securely fastened to the ballast housing with three thumb screws.

INSTALLATION

Refer to the installation manual provided with each luminaire as to the specific method of wiring and mounting the luminaire.

FINISH

The luminaire is finished with polyester powder paint applied after a pretreatment process to insure maximum durability.

UL LISTING

The luminaire is UL listed as suitable for wet location at a maximum 40 degree C ambient temperature.

THIS DRAWING WHEN APPROVED, SHALL BECOME THE COMPLETE SPECIFICATION FOR THE MATERIAL TO BE FURNISHED BY HOLOPHANE ON THE ORDER NOTED ABOVE. A UNIT OF SIMILAR DESIGN MAY BE ORDERED ON THE ORDER NOTED ABOVE. HOLOPHANE WILL BE SUPPLIED WITH EACH ANCHOR BOLT ORDER TO MATCH THE POLE PROVIDED. THIS PRINT IS THE PROPERTY OF HOLOPHANE AND IS LOANED SUBJECT TO RETURN UPON DEMAND AND UPON EXPRESS WRITTEN ORDER. HOLOPHANE ASSUMES NO LIABILITY IN ANY WAY DETRIMENTAL TO OUR INTERESTS, AND ONLY IN CONNECTION WITH MATERIAL FURNISHED BY HOLOPHANE.

ORDER #:	
TYPE:	
DRAWN:	KRW
DATE:	01/24/07
DWG #:	MGM.DWG